

IN THE COUNTY COMMISSION OF WOOD COUNTY, WEST VIRGINIA

#1 COURT SQUARE, SUITE 203
PARKERSBURG WV 26101

IN RE: MINUTES OF MEETING HELD
MONDAY, AUGUST 24, 2015

PRESENT: STEPHEN GAINER, PRESIDENT
DAVID BLAIR COUCH, COMMISSIONER
ROBERT K. TEBAY, COMMISSIONER

At 9:30 A.M., the County Commission of Wood County met in regular session. They signed purchase orders, invoices, orders and other correspondence.

The Oaths of Office for John Pfalzgraf and Terry Moore for the Wood County Airport Authority were received and made of record on this date.

AGENDA AND DISCUSSION ITEMS

The 9:30 A.M., the County Commission announced they will be doing a site visit tomorrow morning at 11:00 A.M. at a construction site by Mondo Construction just outside the City of Williamstown. (Order A/1500)

At 9:36 A.M. the County Commission met with Toni Tiano, Grant Consultant. She requested they sign an Application for this year's Highway Safety Grant in the amount of \$544,000.00. The County Commission authorized the Execution of said Application. (Order M/3182)

At 9:38 A.M., the County Commission met with Randy Atkinson from the Lubeck Public Service District. Mr. Atkinson requested funding for a water main extension on New England

River Road. After discussion, the County Commission agreed to provide \$1,00.00 in self-help funds for the two homeowners who will benefit from this line. (Order M/3182-A)

At 10:17 A.M., the County Commission approved the hiring of Jacqueline Cool and Kim Bolek as Telecommunicators at the E-911 Center.

ORDERS APPROVED AND ATTACHED TO THESE MINUTES

M/3182, M/3182-A, A/1500

Having no further scheduled appointments or business to attend to, the County Commission adjourned at 10:36 A.M.

APPROVED:

THE COUNTY COMMISSION OF WOOD COUNTY



Stephen Gainer, President



David Blair Couch, Commissioner



Robert K. Tebay, Commissioner

To listen to this meeting, please refer to DVD labeled August 24, 2015.

Wood County Commission Meeting
Held August 24, 2015

Please Print

1.	Toni Tamm
2.	
3.	
4.	
5.	
6.	
7.	
8.	
9.	
10.	
11.	
12.	
13.	
14.	
15.	
16.	
17.	
18.	
19.	
20.	



Wood County Commission
Agenda

8/24/2015

1 Court Square, Suite 203
Parkersburg, WV 26101

9:30 A.M.	Administrator's Report	Marty Seufer, County Administrator
<i>CANCELLED</i>	Discuss Development in the County	Mark Mondo
	Request for funding for Water Main Extension on New England River Road	Randy Atkinson, Lubeck Public Service District
	Discuss and Consider Highway Safety Grant Application	Toni Tiano, Grant Consultant
	Consider Request to Hire Jacqueline Cool and Kim Bolek as Telecommunicators at the E-911 Center - \$29,034.72/yr each	
	County Commission Reports	

Discussion, Review and Approval of expenditures and disbursements identified on Exhibit 1, hereto attached

Correspondence for this meeting will be available for public review during regular office hours in Room 205 of the Wood County Courthouse two (2) days prior to the meeting

Exhibit I

Discussion, Review and Approval of the following items may be included during this meeting and are available for public inspection in the Office of the County Administrator two days prior to this meeting.

Budget revisions

Purchase orders and requisitions

Revisions, reimbursement requests, resolutions and correspondence for grants

Grant disbursements to other entities

Invoices for expenditures to be paid

Reimbursements for travel expenses

Bid specifications and procedures for bids previously authorized by the Commission

Monthly Hotel Occupancy Tax Collection disbursements

Disbursements for previously approved Innovative Programming Grants

Tax refunds, exonerations, improprieties and consolidations

Probate items, including settlements, petitions and Fiduciary Commissioner reports

General Fund disbursements to entities

Funding requests from local organizations by written form

Payroll modification as submitted by elected officials

8/24/15
7199

AUGUST 24, 2015

IN THE COUNTY COMMISSION OF WOOD COUNTY, WEST VIRGINIA

IN RE: THE COMMISSION ORDERED THAT A SELF-HELP REQUEST
BE GRANTED TO LUBECK PSD.

ORDER

On this date, the County Commission of Wood County upon a motion made by David Blair Couch, seconded by Robert K. Tebay and made unanimous by Stephen Gainer, did hereby ORDER that a self-help request for funding be granted for a water line extension on New England River Road, by the Lubeck Public Service District.

Said request is for a total of two (2) homes serviced by the extension for a total of one thousand dollars and zero cents (\$1,000.00).

APPROVED:

THE COUNTY COMMISSION OF WOOD COUNTY



Stephen Gainer, President

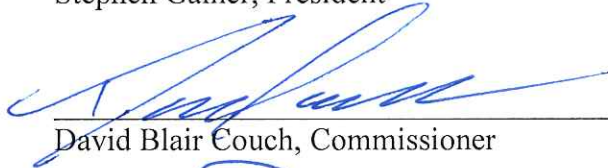

David Blair Couch, Commissioner



Robert K. Tebay, Commissioner

M/3182-A

AUGUST 24, 2015

8/24/15
71/99

IN THE COUNTY COMMISSION OF WOOD COUNTY, WEST VIRGINIA

IN RE: THE COUNTY COMMISSION DID HEREBY AUTHORIZE THE
EXECUTION OF AN APPLICATION FOR A HIGHWAY SAFETY
PROGRAM GRANT

ORDER

On this date, the County Commission of Wood County, upon a motion made by Robert K. Tebay, seconded by Stephen Gainer, and made unanimous by David Blair Couch, did hereby AUTHORIZE the EXECUTION of an Application for a Highway Safety Grant. Said grant is in the amount of five hundred forty-four thousand dollars and zero cents (\$544,000.00).

A copy of said Application is on file in the office of the County Administrator.

APPROVED:

THE COUNTY COMMISSION OF WOOD COUNTY



Stephen Gainer, President

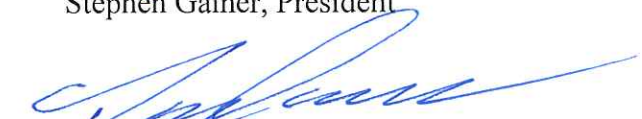

David Blair Couch, Commissioner



Robert K. Tebay, Commissioner

M/3182

Office of the County Commission of Wood County West Virginia

Commissioners
Stephen Gainer
David Blair Couch
Bob Tebay



No. 1 Court Square
Suite 203
Parkersburg, WV 26101
Phone 304-424-1984

8/24/15
71/99

August 24, 2015

Mr. Charlie Kessell
WV Governor's Highway Safety Program
5707 MacCorkle Avenue, SE
PO Box 17600
Charleston, West Virginia
25317-0010

Dear Mr. Kessell:

Please find enclosed an application from the Wood County Commission for the continuation of the Mid-Ohio Valley Regional Highway Safety Program for the period of October 1, 2015 – September 30, 2016. If you have any questions or desire any additional information, please feel free to contact Toni Tiano, program administrator, at 304-481-6409 or 304-424-1972. Thank you for your assistance with this matter.

Sincerely,

Stephen Gainer
President

AUGUST 24, 2015

COUNTY COMMISSION OF WOOD COUNTY, WEST VIRGINIA

RESOLUTION

A RESOLUTION TO AUTHORIZE THE FILING OF A GRANT
APPLICATION BY THE PRESIDENT OF THE WOOD COUNTY
COMMISSION TO THE GOVERNOR'S HIGHWAY SAFETY PROGRAM

Be it resolved by the Wood County Commission, Parkersburg, West Virginia that the President of the Commission, be and is hereby authorize to, submit a grant application to the West Virginia Governor's Highway Safety Program to continue the operation of the Mid-Ohio Valley Regional Highway Safety Program.

Dated this 24th day of August 2015.



Stephen Gainer, President
Wood County Commission

Certified to be a true copy of a Resolution adopted at a regular meeting of the Wood County Commission held on August 24, 2015.



Mark Rhodes, County Clerk
Wood County Commission

GOVERNOR'S HIGHWAY SAFETY PROGRAM
STATE OF WEST VIRGINIA
DIVISION OF MOTOR VEHICLES

Application - Page 1

DATE APPLICATION RECEIVED (For Highway Safety Use Only)

NAME OF APPLICANT: (Must be a government agency)
Wood County Commission

PROJECT TITLE:

Mid-Ohio Valley Regional Highway Safety Program

F.E.I.N. NUMBER:

556000417

FEDERAL FUNDS REQUESTED:

\$ 544,000.00

FEDERAL FUNDS AWARDED:

\$ _____

AUTHORIZED OFFICIAL: (Name, Title, Mailing Address, Zip Code, Phone, Fax & E-mail)

Stephen Gainer, President
Wood County Commission
One Court Square, Suite 203
Parkersburg, West Virginia 26101
304-424-1976
304-424-0194 - fax
seufer@woodcountywv.com

PROJECT DIRECTOR: (Name, Title, Mailing Address, Zip Code, Phone, Fax & E-mail)

Toni Tiano, Consultant
Tiano-Knopp Associates, Inc.
Wood County Courthouse
One Court Square, Suite 203
Parkersburg, West Virginia 26101
304-424-1972/304-481-6409
304-485-2925 - fax
tianoknopp@suddenlink.net

FINANCIAL OFFICER: (Name, Title, Mailing Address, Zip Code, Phone, Fax & E-mail)

Mark Rhodes
Wood County Clerk
Wood County Courthouse
One Court Square
Parkersburg, WV 26101
304-424-1850
304-424-0194
mrhodes@woodcountywv.com

This Section For Highway Safety Use Only

Date Logged In: _____

Conditions & Assurances Signed: _____

Signed Resolution Received: _____

Application Number: _____

Acknowledgement Letter: _____

Copies Distributed To Staff: _____

Application: Approved
Denied

Grant Number: _____

Coordinator Assigned: _____

Special Conditions: Yes
No

Award Letter Dated & Mailed: _____

Process Contract:
To Grantee for Signature: _____
To Commissioner for Signature: _____
Signed Contract to Grantee: _____

FY16 HIGHWAY SAFETY PROGRAM GOALS

Based on 2012/2013/2014 Averages

REGION: 3 – Mid-Ohio Valley Regional Highway Safety Program

Crashes, Injuries, Fatalities

1. Reduce Highway Fatalities from 29 to 26
2. Reduce the Fatality Rate per 100 million VMT from 1.65 to 1.55
3. Reduce Ejections in fatal crashes from 12 to 11
4. Reduce A&B Injuries from 540 to 486
5. Reduce Total injuries from 1,547 to 1,393
6. Reduce Total Crashes from 3,900 to 3,510
7. Reduce Ejections in all crashes from 70 to 63
8. Reduce Speeding-related fatalities from NA to NA
9. Reduce Motorcycle Fatalities from 2 to 1
10. Reduce Unhelmeted Motorcycle Fatalities from 2 to 1
11. Reduce Drivers age 20 or younger involved in fatal crashes from 1 to 0
12. Reduce Pedestrian fatalities from 1 to 0

Alcohol Related

1. Reduce Alcohol Related Fatalities from 6 to 5
2. Reduce the Alcohol Related Fatality Rate from .433 to .389
3. Reduce Alcohol Related Crashes from 205 to 185
4. Reduce Alcohol Related Injuries from 119 to 107
5. Reduce the percentages of underage successful alcohol buys from 15 to 13

Occupant Protection

1. Increase the seat belt usage at Scientific Survey sites from 2 % to 88 %
2. Increase the percentage of Law Enforcement Agencies who participate in the Highway Safety Program to 81 %
3. Oversee the correct installation of **300** Child Passenger Safety Seats & establish a minimum of one CPS Fitting station with advertised times.

Law Enforcement Overtime Activities

1. Decrease the hours per DUI arrest from FY14 7.65 per hour to 7.00 per Hour by the end of FY16
2. Increase the participation of LE Agencies from FY14 16 to 17 agencies by the end of FY16
3. Increase the Number of LE Officers participating from the FY14 level of 98 to 110 by the end of FY16
4. Increase the Number of Occupant Protection Citations from FY14 from 1,711 to 2,000 by the end of FY16
5. Increase the Number of Speeding Citation from FY14 762 to 1,000 by the end of FY16
6. Increase the Number of Red light Citations from FY14 147 to 200 by the end of FY16
7. Increase the Number of total Citations from FY14 6,011 to 7,000 by the end of FY16
8. Increase the number of sobriety checkpoints from FY14 11 to 15 by the end of FY 2016
9. Increase the number of DUI Arrests from FY14 199 to 250 by the end of FY 2016

Each Regional Safe Community Project supported with GHSP funds is ***required*** to conduct the following activities within their assigned region:

COORDINATION / PROJECT DIRECTOR

1. The Project Director must successfully complete a NHTSA Project Management Class.
2. The Project Director must successfully complete a forty (40) hour approved Instructor Development course.
3. Support or establish at least one (1) Advocacy Group (i.e., MADD, SADD, Safe Kids).
4. Establish and maintain a Task Force of Highway Safety advocates and hold a minimum of three (3) meetings per year. A list of members must be maintained on file in the Coordinator's office.
5. Establish and conduct a Regional Highway Safety Award / Recognition program.
6. Make face to face contact with each (100%) Law Enforcement agency (Executive or designee) in the region's service area and secure Letters of Support and Cooperation (and maintained on file).
7. Develop and support one L.E.L. within ***each*** law enforcement agency.
8. Maintain a relationship with DMV Regional Offices in your area through PI&E.
9. Assist the GHSP with the following surveys:
 - a. DMV Driver Attitude Survey (June/July – every other year)
 - b. Statewide Seatbelt Use Survey (June – every year)
10. Provide the GHSP with the following reports by the 20th of each month:
 - Monthly Activity Report
 - Data Report
 - CPS Installations
 - Media Report
 - Equipment Listing
 - Request for Reimbursement
 - Calendar of ***Upcoming*** Events

*All reports are to cover the previous month (i.e. the report for June is due July 20) **except** for the calendar, which should be for the upcoming month (i.e., July calendar of events is due June 20).*

11. Prepare and submit to the GHSP by the C.O.B. on November 1, a detailed Year End report.

ALCOHOL AND OTHER DRUGS

- 1.** Conduct two (2) law enforcement events per week in the Region
- 2.** Conduct two (2) Media activities per month in the Region. Each Coordinator shall attach a dollar value to earned media and track that value. The number of people that received the message is to be tracked also.
- 3.** Conduct two (2) age group activities per year in the Region
- 4.** Each Coordinator shall work with the GHSP LEL Office to facilitate training opportunities for Impaired Driving.
- 5.** Each Coordinator shall ensure Underage enforcement efforts are conducted at least once per quarter.
- 6.** Participate in the state and national mandated blitz periods – Thanksgiving, Christmas/New Year's, WV Day, Fourth of July weekend, and Labor Day. During these periods, all local law enforcement agencies supported by Highway Safety funds shall conduct a minimum of four enforcement events during the blitz/mobilization.
- 7.** Develop and support at a minimum one (1) college PI&E activity.
- 8.** Conduct or facilitate Retail Alcohol Training Activities (i.e. TIPS, WeCard)
- 9.** Assist local law enforcement agencies in obtaining funding from the Commission on Drunk Driving Prevention (CDDP).
- 10.** Complete/submit all DMV Form 314 (DUI Information Sheet). Follow up at the request of GHSP to insure 100% submission. This form is available at www.dmv.wv.gov under Driver Services/Driver's Licenses/Forms.
- 11.** PBT Project – The Governor's Highway Safety Program and the Commission on Drunk Driving Prevention are providing PBT's to local Law Enforcement Agencies. This is an attempt to standardize PBT's in West Virginia.

- a. Each Coordinator shall receive either the training or train someone in their area to calibrate the local LE PBT's in their area.
- b. Each Coordinator shall not support any other type of PBT other than the approved standardized PBT.
- c. Each Coordinator shall assist the GHSP in distributing, tracking, and inventory of the PBT's.

OCCUPANT PROTECTION

1. Participate in the May CIOT Blitz through enforcement and media/public awareness. Provide support and funding to participating law enforcement agencies.
2. Participate in each of the three additional Occupant Protection enforcement waves as outlined in the Strategic Occupant Protection Plan by providing support and funding to participating law enforcement agencies.
3. Conduct "spot check" non-scientific seat belt surveys following each wave to assess results of enforcement.
4. Obtain written seat belt use policies by all law enforcement agencies receiving federal Highway Safety funds, and maintain on file in the Coordinator's office. These policies must be written and outline sanctions for non-compliance.
5. Conduct at least two (2) Earned Media activities per month related to Occupant Protection/seat belt use/seat belt enforcement activities.
6. Conduct at least two (2) PI&E activities per month related to seat belts/child safety seats.
7. Conduct a minimum of four (4) Occupation Protection Informational Checkpoints (i.e. one per quarter).
8. Develop, support, and certify a T.O.P.S. (Traffic Occupant Protection Strategies) instructor, who will conduct a minimum of two (2) T.O.P.S. four (4) hour classes.

9. The Coordinator must complete the thirty-two (32) hour CPS Technician course and remain current with certification.
10. Establish and maintain a minimum of three CPS Fitting Station in the Region.
11. Conduct a minimum of four (4) CPS Clinics/Events.
12. Conduct two "age group" specific activities per year (i.e., visit Drivers Education/High Schools/Middle Schools, Grade Schools; High School Seat Belt Challenge).
13. Conduct two (2) child safety seat classes or demonstrations (i.e. 1 to 8 hours) to a captive audience (i.e. hospital, daycare, church, civic, etc.).
14. Conduct PI&E, Enforcement, and media events during Child Passenger Safety Week in September, including direct participation, if possible, in Seat Check Saturday.
15. Maintain a list of current CPS Technicians in your Region, and increase the number of Certified Technicians in your Region.
16. Conduct Nighttime Seat Belt Enforcement at least twice during the year, in addition to at least once during the May CIOT blitz. Nighttime is considered 6:00 p.m. or after.
17. Encourage enforcement of seat belt laws during all enforcement efforts (DUI, speed, etc.).

MEDIA

1. Facilitate earned media for local, regional and national highway safety activities.
2. Cooperate with the DMV/GHSP Public Information staff in statewide media campaigns.
3. Maintain a media file with all the activity generated by the Regional Program and report the activities to the GHSP Public Information Officer AND GHSP Program Manager on a monthly basis. Share photographs and other media item of events with the GHSP for inclusion on social media pages/Highway Safety publications.

TRAFFIC RECORDS

1. Support efforts to convert law enforcement agencies to electronic reporting.
2. Each Coordinator is to ensure their Region's section of the CDDP/Highway Safety Data Base is maintained in a timely and accurate manner. All information is to

be entered within one week after an activity has occurred and double checked for accuracy.

3. Upon request by the GHSP Director, Coordinators are to facilitate the submission of fatality reports that have not been submitted.

OTHER TRAFFIC SAFETY INITIATIVES

1. Conduct or facilitate a minimum of one ATV Safety Activity yearly.
2. Conduct or facilitate a minimum of one Motorcycle Safety Activity, coordinating with the GHSP Motorcycle Safety Program Manager, i.e., Motorcycle Simulator presentations in Driver's Education classes.
3. Participate in the annual Target Red (Red Light Running) Campaign (generally in August) through enforcement and media activities.
4. Conduct an enforcement campaign during School Bus Safety Week in October.
5. Conduct at least one Distracted Driving (Cell Phone/Texting) enforcement event per quarter.
6. Conduct or facilitate at least one activity/media event on Distracted Driving (Cell Phone/Texting) per quarter.
7. Conduct at least one (1) PI&E/Law Enforcement effort for Back to School in August/September.
8. Conduct a minimum of two (2) Speed/Aggressive Driving Enforcement efforts per year.
9. Based on the identification of a Pedestrian/Bicycle Safety problem in the Region, conduct at least one PI&E event during the year.

REV. 6/15

GOVERNOR'S HIGHWAY SAFETY PROGRAM West Virginia Division of Motor Vehicles STATE OF WEST VIRGINIA		FISCAL SUMMARY Page 4		
SAFE COMMUNITIES 402 Grantee: Wood County Commission Budget Categories: F16-HS-03-402	Estimated Project Costs	Local Funds [Match]	Federal Funds Approved	Highway Safety Account #:
Salaries and Benefits			\$ 36,000.00	SA16-18-03
Project Coordinator Salary	\$ 36,000.00			
Travel & Conferences			\$ 9,000.00	SA16-18-03
Travel Coordinator	\$ 5,000.00			
Other Travel	\$ 4,000.00			
Other Admin Expenditures			\$ 3,350.00	SA16-18-03
Office Administration	\$ 2,000.00			
Storage Units	\$ 1,350.00			
MADD/SADD/Task Force Support			\$ 2,500.00	SA16-18-03
Task Force Support	\$ 2,500.00			
Police and other Training			\$ 2,000.00	PTS16-07-03
LE Training (non-alcohol related)	\$ 2,000.00			
Incentives/Banquets/Awards			\$ 1,000.00	SA16-18-03
Regional Awards Banquets	\$ 1,000.00			
Enforcement			\$ 38,000.00	
Target Red Enforcement	\$ 15,000.00			PTS16-07-03
National Blitz August 1-14, 2016				
Speed Enforcement	\$ 20,000.00			SE16-21-03
School Bus Safety Enforcement (October)	\$ 1,000.00			SB16-19-03
October 19-23, 2015				
Back To School Safety Enforcement	\$ 2,000.00			SB16-19-03
Public Information & Education			\$ 10,000.00	MC16-04-03
ATV/Bicycle Safety/OP/Pedestrian PI&E	\$ 10,000.00			
Yellow DOT Program			\$ 600.00	OP16-05-03
Yellow DOT Equipment	\$ 300.00			
Yellow DOT Supplies	\$ 300.00			
Paid Media			\$ 10,000.00	PM16-26-03
Occupant Protection	\$ 5,000.00			
Misc. - Bike Safety/ATV/Back to School/e	\$ 5,000.00			
TOTAL PROJECT COSTS:	\$ 112,450.00			
TOTAL LOCAL FUNDS:		\$ -	\$ -	
TOTAL FEDERAL FUNDS:			\$ 112,450.00	
TOTAL APPROVED PROJECT:			\$ 112,450.00	

CPS Technician Training/Recertifications West Virginia Division of Motor Vehicles STATE OF WEST VIRGINIA		FISCAL SUMMARY Page 4		
MAP21 OCCUPANT PROTECTION 405b Grantee: Wood County Commission Budget Categories: F16-HS-03-405b	Estimated Project Costs	Local Funds [Match]	Federal Funds Approved	Highway Safety Account #:
Fitting Station/CPS Recerts/Clinics/PI&E			\$ 5,500.00	CPS16-04-03
CPS Technician Training/Recertifications	\$ 1,500.00			
Fitting Station Supplies/Incentives	\$ 1,000.00			
Child Seat OT	\$ 3,000.00			
Enforcement			\$ 35,000.00	HV16-01-03
CIOT May Blitz (May 16-30, 2016)	\$ 20,000.00			
CIOT Mini Waves				
November 6-22, 2015	\$ 5,000.00			
March 4-20, 2016	\$ 5,000.00			
August 12-18, 2016	\$ 5,000.00			
Public Info & Education			\$ 4,500.00	PE16-03-03
CPS PI&E	\$ 500.00			
Child Safety PI&E	\$ 4,000.00			
High School/College Safety Efforts			\$ 3,000.00	PE16-03-03
High School Challenge	\$ 3,000.00			
TOTAL PROJECT COSTS:	\$ 48,000.00			
TOTAL LOCAL FUNDS:		\$ -	\$ -	
TOTAL FEDERAL FUNDS:			\$ 48,000.00	
TOTAL APPROVED PROJECT:			\$ 48,000.00	

GOVERNOR'S HIGHWAY SAFETY PROGRAM
 West Virginia Division of Motor Vehicles
 STATE OF WEST VIRGINIA

FISCAL SUMMARY
 Page 4

SEATBELT PERFORMANCE INCENTIVES 406 Grantee: Wood County Commission Budget Categories: F16-HS-03-406	Estimated Project Costs	Local Funds [Match]	Federal Funds Approved	Highway Safety Account #:
Child Safety Seat Purchases Child Safety Seat Purchases	\$ 6,000.00		\$ 6,000.00	CR16-23-03
TOTAL PROJECT COSTS:	\$ 6,000.00			
TOTAL LOCAL FUNDS:		\$ -	\$ -	
TOTAL FEDERAL FUNDS:			\$ 6,000.00	
TOTAL APPROVED PROJECT:			\$ 6,000.00	

GOVERNOR'S HIGHWAY SAFETY PROGRAM
 West Virginia Division of Motor Vehicles
 STATE OF WEST VIRGINIA

FISCAL SUMMARY
 Page 4

TRAFFIC SAFETY DATA SYSTEMS 408 Grantee: Wood County Commission Budget Categories: F16-HS-03-408	Estimated Project Costs	Local Funds [Match]	Federal Funds Approved	Highway Safety Account #:
Equipment and Software Electronic Equipment	\$ 95,000.00		\$ 95,000.00	K916-01-03
Police and Other Training Traffic Records Training/Installation	\$ 5,000.00		\$ 5,000.00	K916-01-03
TOTAL PROJECT COSTS:	\$ 100,000.00			
TOTAL LOCAL FUNDS:		\$ -	\$ -	
TOTAL FEDERAL FUNDS:			\$ 100,000.00	
TOTAL APPROVED PROJECT:			\$ 100,000.00	

GOVERNOR'S HIGHWAY SAFETY PROGRAM
West Virginia Division of Motor Vehicles
STATE OF WEST VIRGINIA

FISCAL SUMMARY

Page 4

ALCOHOL 410 Grantee: Wood County Commission Budget Categories: F16-HS-03-410	Estimated Project Costs	Local Funds [Match]	Federal Funds Approved	Highway Safety Account #:
DUI HVE Enforcement			\$ 10,000.00	HV16-01-03
DUI Enforcement HVE (can be used anywl	\$ 10,000.00			
Enforcement			\$ 1,000.00	K816-01-03
DRE Enforcement	\$ 1,000.00			
Training			\$ 14,000.00	K816-01-03
Impaired Driver Training	\$ 5,000.00			
DRE Training/Travel	\$ 9,000.00			
TOTAL PROJECT COSTS:	\$ 25,000.00			
TOTAL LOCAL FUNDS:		\$ -	\$ -	
TOTAL FEDERAL FUNDS:			\$ 25,000.00	
TOTAL APPROVED PROJECT:			\$ 25,000.00	

GOVERNOR'S HIGHWAY SAFETY PROGRAM West Virginia Division of Motor Vehicles STATE OF WEST VIRGINIA		FISCAL SUMMARY Page 4		
ALCOHOL TRANSFER FUNDS 154 Grantee: Wood County Commission Budget Categories: F16-HS-03-154	Estimated Project Costs	Local Funds [Match]	Federal Funds Approved	Highway Safety Account #:
Enforcement			\$ 79,300.00	AL16-02-03
DUI Enforcement	\$ 60,000.00			
Dec. 18, 2015 - Jan. 3, 2016 DSOGPO National Enforcement Crackdown				
Aug. 17 - Sept. 5, 2016 DSOGPO National Enforcement Crackdown				
Thanksgiving, West Virginia Day and Fourth of July weekend (state crackdowns)				
Sobriety Checkpoints	\$ 15,000.00			
Underage Compliance Checks	\$ 3,000.00			
Underage Stipends	\$ 300.00			
PBT Recalibrations	\$ 1,000.00			
Travel/Conferences			\$ 10,000.00	AL16-02-03
Statewide DUI Conference	\$ 10,000.00			
Incentives			\$ 55,000.00	AL16-02-03
Agency Incentives	\$ 50,000.00			
Officer Incentives	\$ 5,000.00			
High School/College Safety Efforts			\$ 5,000.00	AL16-02-03
High School/College Projects - Alcohol education	\$ 5,000.00			
Police and Other Training			\$ 750.00	AL16-02-03
TIPS	\$ 750.00			
Public Info & Education			\$ 7,500.00	AL16-02-03
Alcohol-related PI&E	\$ 7,500.00			
Paid Media			\$ 10,000.00	PM16-03-03
Alcohol-Related	\$ 10,000.00			
TOTAL PROJECT COSTS:	\$ 167,550.00			
TOTAL LOCAL FUNDS:		\$ -	\$ -	
TOTAL FEDERAL FUNDS:			\$ 167,550.00	
TOTAL APPROVED PROJECT:			\$ 167,550.00	

GOVERNOR'S HIGHWAY SAFETY PROGRAM
West Virginia Division of Motor Vehicles
STATE OF WEST VIRGINIA

FISCAL SUMMARY
 Page 4

DIV OF HIGHWAYS-DISTRACTED DRIVING Grantee: Wood County Commission Budget Categories: F16-HS-03-DOHDD	Estimated Project Costs	Local Funds [Match]	Federal Funds Approved	Highway Safety Account #:
Enforcement			\$ 50,000.00	DD16-01-03
Distracted Driving Enforcement	\$ 50,000.00			
National Distracted Driving Month April 2016				
Paid Media			\$ 3,000.00	PM16-02-03
Distracted Driving Radio/TV PSAs	\$ 3,000.00			
High School Projects			\$ 12,000.00	DD16-01-03
Alliance Sports Marketing	\$ 12,000.00			
TOTAL PROJECT COSTS:	\$ 65,000.00			
TOTAL LOCAL FUNDS:		\$ -	\$ -	
TOTAL FEDERAL FUNDS:			\$ 65,000.00	
TOTAL APPROVED PROJECT:			\$ 65,000.00	

GOVERNOR'S HIGHWAY SAFETY PROGRAM
 West Virginia Division of Motor Vehicles
 STATE OF WEST VIRGINIA

FISCAL SUMMARY
 Page 4

DIV OF HIGHWAYS-WORK ZONE SAFETY Grantee: Wood County Commission Budget Categories: F16-HS-03-DOHWZ	Estimated Project Costs	Local Funds [Match]	Federal Funds Approved	Highway Safety Account #:
Enforcement Work Zone Enforcement	\$ 20,000.00		\$ 20,000.00	WZ16-01-03
TOTAL PROJECT COSTS:	\$ 20,000.00			
TOTAL LOCAL FUNDS:		\$ -	\$ -	
TOTAL FEDERAL FUNDS:			\$ 20,000.00	
TOTAL APPROVED PROJECT:			\$ 20,000.00	

CONDITIONS & ASSURANCES

The applicant hereby certifies and assures that it shall comply with the following regulations, policies, guidelines and requirements of the Governor's Highway Safety Program as further clarified in the Highway Safety Administrative Manual.

1. The applicant hereby certifies it has legal authority to apply for the grant: that a resolution, motion or similar action has been duly adopted or passed as an official act of the applicant's governing body, authorizing the filing of this proposal/application, including all understandings and assurances contained therein, and directly authorizes the person identified as the authorized representative of the applicant to act in connection with the application and to provide such additional information as may be required.
2. **RELATIONSHIP.** The relationship of the Sub-Grantee to the Governor's Highway Safety Program shall be that of an independent contractor, not that of a joint enterprise. The Sub-Grantee shall have no authority to bind the Governor's Highway Safety Program for any obligation or expense without the express prior written approval of the Governor's Highway Safety Program.
3. **LAW OF WEST VIRGINIA.** The proposal/application/contract shall be governed in all respects by the laws of the State of West Virginia. State procedures and practices will apply to all funds disbursed by the Governor's Highway Safety Program.
4. **ACCESS TO RECORDS.** The Governor's Highway Safety Program through any authorized representative will have access to and the right to examine all records, books or documents related to the proposal/application/contract/grant, and to relevant books and records of contractors.
5. **USE OF FUNDS.** Funds awarded by the Governor's Highway Safety Program may be extended only for the purpose and activities specifically covered by the Sub-Grantee's approved project description and budget.
6. **ALLOWABLE/UNALLOWABLE COSTS.** The allowability/unallowability of costs incurred under this grant shall be determined in accordance with general principles and standards for selected cost items set forth in the Highway Safety Administrative Manual.
7. **REPORTS & SUSPENSIONS.** The Sub-Grantee shall submit, at such times and in such form as may be prescribed, such reports as the Governor's Highway Safety Program may reasonably require, including but not limited to fiscal and program progress reports. Failure to submit any required report (i.e. Progress, Fiscal, Activity, etc.) by close of business (C.O.B.) on the designated due date may result in suspension of the project. To reinstate the project, a letter of explanation signed by the Authorized Official, the Project Director, and the Fiscal Director must be submitted promptly to the Governor's Highway Safety Program. More than one suspension in any twelve (12) month project period will automatically terminate the project for the remainder of the project's funding period.
8. **SANCTIONS FOR NONCOMPLIANCE.** In the event of the Sub-Grantee's noncompliance with the terms, conditions, covenants, rules or regulations of this grant, the Governor's Highway Safety Program shall impose such contract sanctions as it may deem appropriate, including but not limited to:
 - a) Withholding of payments to the Sub-Grantee until the Sub-Grantee complies, or
 - b) Cancellation, termination or suspension of the contract in whole or in part, or
 - c) Refrain from extending any further assistance to the Sub-Grantee until satisfactory assurance of future compliance has been received from the Sub-Grantee.
9. **WRITTEN APPROVAL OF CHANGES.** The Sub-Grantee must obtain prior written approval from the Governor's Highway Safety Program for **all** changes relating to the scope of the project and for **all** financial adjustments between major budget categories.
10. **MATCHING CONTRIBUTION.** The Sub-Grantee will have available, and will expend as needed, adequate resources to defray that portion of the total costs as set forth in the proposal as "Local Funds" and as approved by the Governor's Highway Safety Program.

11. **PROJECT INCOME.** All income earned by the Sub-Grantee as a result of the conduct of this project, must be accounted for and included in the total budget.
12. **DISCRIMINATION PROHIBITED.** No person shall, on the grounds of race, color, sex or national origin, be excluded from participation in, be refused the benefits of, or to be otherwise subjected to discrimination under grants awarded by the Governor's Highway Safety Program.
13. **AUDIT.** It is the responsibility of the Sub-grantee to provide for the performance of an independent audit as detailed in the Highway Safety Administrative Manual. The Sub-Grantee further agrees to submit a copy of each audit to the Governor's Highway Safety Program, including a systematic statement for the timely and appropriate resolution of findings or recommendations.
14. **CONSULTANT/CONTRACTS.** No agreement or contract may be entered into by the Sub-Grantee for the execution of project activities or provisions of service which is not incorporated in the approved grant, and/or without the prior written permission of the Governor's Highway Safety Program. Grant approval does not constitute consultant/contract approval.
15. **PROPERTY ACCOUNTABILITY.** The Sub-Grantee shall establish and administer a system to control, protect, preserve, use, maintain, and dispose of any property or equipment furnished by the Governor's Highway Safety Program. The obligation continues as long as the property is retained by the Sub-Grantee notwithstanding the expiration of this agreement. Prior to the sale, trade-in, or disposal of property, disposition instructions will be obtained from the Governor's Highway Safety Program. The Sub-Grantee assures that all property shall be made available to the Governor's Highway Safety Program for inspection/inventory at the request of the Governor's Highway Safety Program.
16. **ACCOUNTING REQUIREMENTS.** Sub-Grantee agrees to record all project funds and costs following generally accepted accounting principles. A separate account number or cost recording must separate all project costs from the Sub-Grantee's other or general expenditures. Adequate documentation for all project costs and incomes must be maintained. Adequate documentation of financial and supporting materials, as defined in the Highway Safety Administrative Manual, must be retained and be available for audit purposes.
17. **OBLIGATION OF PROJECT FUNDS.** Funds may not, without prior written approval from the Governor's Highway Safety Program, be obligated prior to the effective date or subsequent to the termination date of the project period. Obligations outstanding as of the termination date shall be liquidated within thirty days.
18. **ASSUMPTION OF FUNDING.** The Sub-Grantee will assume the funding of improvements after a reasonable period of assistance.
19. **REPORTING OF IRREGULARITIES.** Sub-Grantees are responsible for reporting promptly to the Governor's Highway Safety Program the nature and circumstances surrounding any fiscal irregularities discovered. Failure to report known irregularities may result in suspension of the grant or other remedial action determined by the Governor's Highway Safety Program.
20. **PUBLIC AVAILABILITY OF INFORMATION.** The Sub-Grantee agrees to comply with the terms and conditions of pertinent Federal and State Freedom of Information Acts, and to require its contractors to comply with these requirements.
21. **CONFLICT OF INTEREST.** No public official or employee of the State of West Virginia, who performs any duties under the project, may participate in any administrative decision with respect to this project, if such a decision can be expected to result in any benefit or remuneration to him or his or his immediate family.
22. **CANCELLATION PROVISION.** If this project is not started within thirty days of the grant award, the Sub-Grantee will report to the Governor's Highway Safety Program by letter the steps taken to initiate the project. If after sixty days from the date of the grant award the project is still not operational, a further statement explaining the delay will be submitted by the Sub-Grantee to the Governor's Highway Safety Program. Upon receipt of the sixty-day letter, and unless warranted by extenuating circumstances, the Governor's Highway Safety Program will cancel the project and redistribute the funds to other projects.
23. **CRIMINAL PENALTIES.** Whoever embezzles, willfully misapplies, steals or obtains by fraud any funds, assets or property which are the subject of this grant, or whoever knowingly and willingly falsifies, conceals or covers up by trick, scheme, or device any material fact in any application/contract for assistance submitted to the Governor's Highway Safety Program shall be subject to prosecution.

GOVERNOR'S HIGHWAY SAFETY PROGRAM

STATE OF WEST VIRGINIA
DIVISION OF MOTOR VEHICLES

Application - Page 7

24. **MEETINGS.** Sub-Grantee assures that the Project Director, Fiscal Officer (or designee), and/or the Authorized Official (or designee) will attend any meeting, conference, workshop, or other similar function as deemed necessary by the Governor's Highway Safety Program for administration of this project. Additionally, the Sub-Grantee assures that the Project Director will cooperate and fully participate with staff of the Governor's Highway Safety Program and Law Enforcement Liaisons during statewide initiatives and campaigns.
25. **TRAVEL.** All out of state travel to be reimbursed under any Highway Safety grant must receive written approval in advance from the Governor's Highway Safety Program. All estimated travel expenses (per diem, registration, transportation, etc.) must be included with the request for out of state travel. All Requests for Reimbursements for travel expenses must be submitted to the Governor's Highway Safety Program within 2 months of the travel dates.
26. **PARTICIPATION.** Law enforcement agencies/officers must be an active participant in Highway Safety/NHTSA funded initiatives in order to receive any Highway Safety Program/NHTSA funded benefit, such as highway safety related equipment, training, conference attendance, reimbursement for enforcement (not to exceed the officer's time and one half rate of pay), etc.
27. **STATEWIDE MEDIA.** Statewide media costs incurred by the GHSP are accepted and recognized by the Grantee as a supplemental benefit to complement their local and regional law enforcement efforts.
28. **SEAT BELT POLICY.** Any law enforcement agency receiving Highway Safety funds must have a written seat belt use policy in place for their agency. A copy of this policy, which must outline sanctions for non-compliance with the policy, must be on file with their respective Regional Coordinator.
29. **REGIONAL COORDINATOR.** In the event that the position of Regional Coordinator becomes available, the Governor's Highway Safety Program must be involved in the selection process of filling the position, and must give final approval of hiring the individual selected.
30. **REQUIRED ACTIVITIES.** Failure to complete the "Coordinator's Required Activities" may result in temporary or permanent suspension of the program. It is imperative to the success of the Highway Safety Program that these activities be implemented. If a particular activity cannot be completed, a written detailed explanation must be submitted to the Program Manager as to why it cannot be completed.
31. **FINAL REQUEST FOR REIMBURSEMENT.** Sub-grantees must submit a Final Request for Reimbursement to the Governor's Highway Safety Program no later than November 15 for the preceding fiscal year, and must include **all** expenditures made prior to October 1. Any Request for Reimbursement submitted after November 15 for funds expended prior to October 1 of the preceding fiscal year will be denied.
32. **EQUIPMENT.** Computers/laptops/tablets may not be purchased by any sub-grantee without prior written approval by the Director, Federal Programs Administrator, or State Programs Administrator of the GHSP. Any equipment with a total cost of \$5,000 or more per item must receive written prior approval from the NHTSA Region 3 office (and submitted by the GHSP). Additionally, any individual item costing \$5,000 or more must meet the **BUY AMERICA** guidelines set forth by NHTSA.

In accordance with the Conditions and Assurance Pages 5 - 7, and without limiting same, we certify this application is an accurate and complete description of the project to be considered for receiving Highway Safety funds. We further agree this application shall be binding upon the applicant, assignees, transferees, lessees, and successors in interest. These assurances shall also be binding through every modification or amendment to the project.

Signature of Authorized Official
(Required)

8/24/15
Date

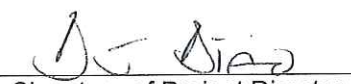
Signature of Project Director
(Required)

8/24/15
Date

Special Conditions

Stephen Garner
Signature of Authorized Official
(Required)

8/24/15
Date

DC DIAO
Signature of Project Director
(Required)

8/24/15
Date



1350 Market Street
Parkersburg, WV 26101
304/428-7760
304/485-2925 – fax
304/481-6409- cell
tianoknopp@suddenlink.net

AGREEMENT

THIS AGREEMENT, is made and entered into this 1st day of October 2015, by and between the Wood County Commission of Wood County, West Virginia, (hereinafter “Commission”) and Tiano-Knopp Associates, Inc., located at 1350 Market Street, Parkersburg, West Virginia 26101 (hereinafter “TKA”).

RECITALS

1. Whereas the Commission is the recipient of grant funds from the State of West Virginia’s Department of Transportation - Division of Motor Vehicles – WV Highway Safety Program - for the purpose of operating a Highway Safety/Safe Community Program in the Mid-Ohio Valley Region of West Virginia.
2. Whereas TKA is in the business of providing administrative and management consultation services regarding overseeing the grant and its activities.
3. Whereas the parties desire that TKA provide these services for the Commission to benefit the efforts regarding the aforementioned program.

Page Two

NOW THEREFORE, in consideration of the promises made each to the other and other good and valuable consideration, the Commission and TKA hereby agree as follows:

SERVICES

TKA shall provide administrative, management, and project oversight services to the Commission regarding their grantee status as to this program.

Some of the items will include:

- Assembly of information from funded components of the Highway Safety Grant.
- Coordination of the distribution of grant funds to the program components.
- Coordination of the receipt of funds by program components.
- Coordination and oversight of all program components and activities of the grant.
- Coordination of quality assurances and report of funded components.
- Coordination of all reports to be made to the appropriate agent of the grant.
- Coordination of all planning and actual activities as outlined in the grant.
- Coordination of planning for continuance of grantee status for the Commission for the subsequent grant years.
- Coordination of the development for new programs for future consideration by the approved agent of the grantee.
- Any other activity, project, etc. which is required by the grant guidelines and/or may be necessary for the successful operation of the highway safety/safe community program.

MATERIALS

All materials that are necessitated in the carrying out of the service provisions of this Agreement shall be structured to be funded as indicated in the provisions of the grant.

TRAVEL/TRAINING

Grant funds shall be provided for travel and training of TKA and other appropriate individuals. West Virginia State Travel Regulations shall be followed as well as other guidelines and requirements of the Governor's Highway Safety Program.

COMPENSATION

The Commission shall compensate TKA the sum of \$36,000 from the Highway Safety Grant funds for 1,920 hours of service throughout the year.

TKA shall submit monthly time sheets, invoices, and appropriate grant reports for payment purposes. Upon review of these documents, they will be forwarded to the Commission for their approval and payment. These invoices shall be paid in accordance with the Grant Program guidelines.

Additional funds been earmarked for overtime funds for TKA to perform child safety seat clinics during evening/weekend hours. The hourly rate for these clinics shall be \$28.13. A separate invoice shall be submitted each month for any of these hours worked during the previous month.

TERM OF AGREEMENT

This Agreement shall begin October 1, 2015 and will terminate on September 30, 2016. If, however, any of the following circumstances arise, this Agreement may be terminated at an earlier date.

1. This Agreement may be terminated for just cause by either party upon thirty (30) days written notice given by one party to the other.

2. If for any reason the Commission shall lose the funding provided for this Program from the WVDOT, this contract shall terminate immediately.

Page Four

3. If TKA does not comply fully with the mandated services of this Agreement, the Commission shall terminate this Agreement immediately upon the written notice being provided to TKA by the Commission of such reason.

4. This Agreement may also be terminated upon circumstances beyond the control of TKA such as her death or disability precluding continuation of services to be provided.

5. In any of the above circumstances, damages shall be limited to payment for services rendered as of the date of termination.

If for any reason the conditions or provisions of this Agreement are not carried out by TKA, the Commission shall pursue all administrative, contractual, and legal remedies available by law, including such sanctions and penalties which may be available through these remedies.

MODIFICATIONS TO AGREEMENT

The terms contained in this Agreement may be modified or amended at any time by mutual consent of the Commission and TKA. Any change or amendment shall be reduced in writing and signed by all parties and made part of this Agreement.

IN WITNESS WHEREOF, the parties hereto have signed this Agreement on this the 24th day of August 2015.



By Its President:

Stephen Gainer

County Commission of Wood County
West Virginia

Page Five



Tiano-Knopp Associates, Inc.

COMPENSATION October 1, 2015 - September 30, 2016: \$36,000.00

October 2015	\$3,150.00
November 2015	\$3,000.00
December 2015	\$2,850.00
January 2016	\$3,000.00
February 2016	\$3,000.00
March 2016	\$3,300.00
April 2016	\$3,000.00
May 2016	\$3,450.00
June 2016	\$3,000.00
July 2016	\$2,250.00
August 2016	\$3,150.00
September 2016	\$2,850.00

Check Register Report for Wood County Commission

Check No	Vendor Id	Vendor Name	Type	Check Date	Check Amount	Rec
5987	UNITED BANK	UNITED BANKCARD CENTER	REGULAR	08/17/2015	1,149.09	

JOMM.CRIMINAL JUSTICE FUND Bank Id 172 Totals

1,149.09

Two handwritten signatures in black ink are present on the page. The top signature is a cursive name, possibly 'E. H. ...', and the bottom signature is another cursive name, possibly 'R. H. ...'. Both signatures are slanted to the right.

Check Register Report for Wood County Commission

Check No	Vendor Id	Vendor Name	Type	Check Date	Check Amount	Rec
3212	UNITED BANK	UNITED BANKCARD CENTER	REGULAR	08/17/2015	218.70	

HOME CONFINEMENT Bank Id 108 Totals

218.70

Two handwritten signatures in black ink, one above the other, located in the lower right quadrant of the page.

Check Register Report for Wood County Commission

Check No	Vendor Id	Vendor Name	Type	Check Date	Check Amount	Rec
6270	UNITED BANK	UNITED BANKCARD CENTER	REGULAR	08/17/2015	15,372.35	

E-911 FUND Bank Id 107 Totals 15,372.35

Two handwritten signatures in black ink, one above the other, located in the lower right quadrant of the page.

Check Register Report for Wood County Commission

Check No	Vendor Id	Vendor Name	Type	Check Date	Check Amount	Rec
158681	UNITED BANK	UNITED BANKCARD CENTER	REGULAR	08/17/2015	19,865.31	

GENERAL FUND Bank Id 101 Totals

19,865.31

[Handwritten signature]
[Handwritten signature]

Check Register Report for Wood County Commission

Check No	Vendor Id	Vendor Name	Type	Check Date	Check Amount	Rec
5988	ALCOHOLMONIT	ALCOHOL MONITORING SYSTEMS	REGULAR	08/18/2015	131.75	
5989	DOMINIONH	DOMINION HOPE	REGULAR	08/18/2015	13.64	
5990	LANCE	PHYLISS LANCE	REGULAR	08/18/2015	550.00	
5991	MONPOWER	MON POWER	REGULAR	08/18/2015	1,405.53	
5992	MOUNTAINEERC	MOUNTAINEER GAS COMPANY	REGULAR	08/18/2015	33.44	
5993	ODEPOT	OFFICE DEPOT	REGULAR	08/18/2015	140.77	
5994	OLD COLONY J	OLD COLONY REALTORS	REGULAR	08/18/2015	1,100.00	
5995	PARKERSBU	PARKERSBURG UTILITY BOARD	REGULAR	08/18/2015	149.80	
5996	RICOH	RICOH USA INC	REGULAR	08/18/2015	581.02	
5997	SASSI	SASSI INSTITUTE	REGULAR	08/18/2015	370.00	
5998	SINGERJ	JANA SINGER-DOWLER	REGULAR	08/18/2015	44.00	
5999	SUDDENLINKD	SUDDENLINK	REGULAR	08/18/2015	205.72	
6000	TIANO	TIANO-KNOPP ASSOC., INC.	REGULAR	08/18/2015	417.00	
6001	TYLER	TYLER MOUNTAIN WATER CO INC	REGULAR	08/18/2015	26.24	
6002	VERIZONW	VERIZON WIRELESS	REGULAR	08/18/2015	57.02	
6003	WOOD CO S	WOOD CO SENIOR CITIZENS ASSOCIATION INC.	REGULAR	08/18/2015	1,500.00	
6004	WVCBAPP	West Virginia Certification Board for Addiction &	REGULAR	08/18/2015	200.00	
COMM.CRIMINAL JUSTICE FUND Bank Id 172 Totals					6,725.93	

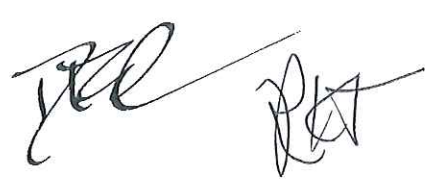

Check Register Report for Wood County Commission

Check No	Vendor Id	Vendor Name	Type	Check Date	Check Amount	Rec
3213	3M	3M ELECTRONIC MONITORING	REGULAR	08/18/2015	3,609.60	
3214	BATTERIES	BATTERIES DIRECT	REGULAR	08/18/2015	60.00	
3215	CCF	COMMUNITY CORRECTIONS FUND	REGULAR	08/18/2015	1,554.00	
3216	VERIZONW	VERIZON WIRELESS	REGULAR	08/18/2015	250.96	
HOME CONFINEMENT Bank Id 108 Totals					5,474.56	



Two handwritten signatures in black ink, one above the other, located in the lower right quadrant of the page.

Check Register Report for Wood County Commission

Check No	Vendor Id	Vendor Name	Type	Check Date	Check Amount	Rec
6271	CAPITAL	CAPITAL RESERVE FUND	REGULAR	08/18/2015	250,000.00	
6272	MOTOROLA	MOTOROLA SOLUTIONS INC	REGULAR	08/18/2015	297.00	
6273	NETWORK A	NETWORK ASSOCIATES	REGULAR	08/18/2015	60.00	
6274	NI GOVERNMENT	NI GOVERNMENT SERVICE INC	REGULAR	08/18/2015	895.56	
6275	ODEPOT	OFFICE DEPOT	REGULAR	08/18/2015	70.14	
6276	ONESOURCE	ONESOURCE WATER	REGULAR	08/18/2015	62.10	
6277	REYNOLDSL	REYNOLDS LANDSCAPING	REGULAR	08/18/2015	830.00	
6278	TESSCO	TESSCO TECHNOLOGIES	REGULAR	08/18/2015	64.98	
6279	VERIZONW	VERIZON WIRELESS	REGULAR	08/18/2015	343.54	
E-911 FUND Bank Id 107 Totals					252,623.32	

Check Register Report for Wood County Commission

Check No	Vendor Id	Vendor Name	Type	Check Date	Check Amount	Rec
729	HUMANE SO	HUMANE SOCIETY	REGULAR	08/18/2015	3,333.33	
DOG FUND Bank Id 103 Totals					3,333.33	

[Handwritten signature]
[Handwritten initials]

Check Register Report for Wood County Commission

Check No	Vendor Id	Vendor Name	Type	Check Date	Check Amount	Rec
158682	BAILEY	BAILEY INSURANCE AGENCY	REGULAR	08/18/2015	1,803.69	
158683	CANON	CANON FINANCIAL SERVICES, INC	REGULAR	08/18/2015	220.55	
158684	CHAPMAN	CHAPMAN PRINTING CO. INC	REGULAR	08/18/2015	285.02	
158685	CWS	CWS	REGULAR	08/18/2015	50.00	
158686	DECKS DIRECT	DECKS DIRECT	REGULAR	08/18/2015	1,682.95	
158687	DODDRIDGE	DODDRIDGE COUNTY SHERIFF DEPARTMENT	REGULAR	08/18/2015	91.08	
158688	ENVIROSIGNS	ENVIRO SIGNS	REGULAR	08/18/2015	10,164.55	
158689	FERGUSOND	DAVID FERGUSON	REGULAR	08/18/2015	700.00	
158690	GLACIER	GLACIER MOUNTAIN BOTTLED WATER	REGULAR	08/18/2015	13.00	
158691	HUMANE SO	HUMANE SOCIETY	REGULAR	08/18/2015	19,250.00	
158692	JCSO	JACKSON COUNTY SHERIFF'S DEPT	REGULAR	08/18/2015	548.22	
158693	KINCHELOE	KINCHELOE MOTORS INC.	REGULAR	08/18/2015	494.60	
158694	LAMBERTTAT	LAMBERT TATMAN FUNERAL HOME	REGULAR	08/18/2015	250.00	
158695	LAMP	LAMP PESTPROOF	REGULAR	08/18/2015	75.00	
158696	LEWISCOCIRCLK	LEWIS COUNTY CIRCUIT CLERK	REGULAR	08/18/2015	41.08	
158697	MAHONE TI	MAHONE TIRE CO	REGULAR	08/18/2015	56.00	
158698	MID-OHIOVRA	MID-OHIO VALLEY REGIONAL AIRPORT	REGULAR	08/18/2015	850.00	
158699	MILLER CO	MILLER COMMUNICATIONS IN	REGULAR	08/18/2015	130.00	
158700	MYERS SEP	MYERS SEPTIC	REGULAR	08/18/2015	165.00	
158701	ODEPOT	OFFICE DEPOT	REGULAR	08/18/2015	79.20	
158702	ONESOURCE	ONESOURCE WATER	REGULAR	08/18/2015	192.35	
158703	PARKSHARD	PARKS HARDWARE & SUPPLY	REGULAR	08/18/2015	23.23	
158704	PCSD	PLEASANTS COUNTY SHERIFF'S DEPARTMENT	REGULAR	08/18/2015	99.16	
158705	RICOH	RICOH USA INC	REGULAR	08/18/2015	178.00	
158706	RITCHIE CO	RITCHIE COUNTY SHERIFF'S DEPT	REGULAR	08/18/2015	43.26	

JED



WKA

Check Register Report for Wood County Commission

Check No	Vendor Id	Vendor Name	Type	Check Date	Check Amount	Rec
158707	S W RESOU	S W RESOURCES	REGULAR	08/18/2015	96.00	
158708	SAMS CLUB	SAM'S CLUB	REGULAR	08/18/2015	226.67	
158709	SPENCER PD	SPENCER POLICE DEPARTMENT	REGULAR	08/18/2015	351.53	
158710	ST.CLAIR	MICHAEL ST. CLAIR	REGULAR	08/18/2015	240.00	
158711	STATE AUD	STATE AUDITOR'S OFFICE	REGULAR	08/18/2015	600.00	
158712	SUDDENLINKD	SUDDENLINK	REGULAR	08/18/2015	122.70	
158713	SWIGER M	MELVIN SWIGER	REGULAR	08/18/2015	40.26	
158714	VERIZONW	VERIZON WIRELESS	REGULAR	08/18/2015	2,968.20	
158715	VIENNA	VIENNA POLICE DEPT.	REGULAR	08/18/2015	710.55	
158716	VILLERS	CHARLENE VILLERS	REGULAR	08/18/2015	220.89	
158717	WATERBOY	WATERBOY LLC	REGULAR	08/18/2015	22.00	
158718	WEST	THOMSON REUTERS - WEST PAYMENT CENTER	REGULAR	08/18/2015	626.61	
GENERAL FUND Bank Id 101 Totals					63,711.35	

Check Register Report for Wood County Commission

Check No	Vendor Id	Vendor Name	Type	Check Date	Check Amount	Rec
1720	DENTAL	RENAISSANCE	REGULAR	08/19/2015	1,354.20	
1721	MONPOWER	MON POWER	REGULAR	08/19/2015	10.60	
GENERAL FUND Bank Id 101 Totals					1,364.80	
Report Totals					1,364.80	

AUGUST 24, 2015

IN THE COUNTY COMMISSION OF WOOD COUNTY, WEST VIRGINIA

IN RE: THE COUNTY COMMISSION DID HEREBY AUTHORIZE THE
EXECUTION OF AN APPLICATION FOR A HIGHWAY SAFETY
PROGRAM GRANT

ORDER

On this date, the County Commission of Wood County, upon a motion made by Robert K. Tebay, seconded by Stephen Gainer, and made unanimous by David Blair Couch, did hereby AUTHORIZE the EXECUTION of an Application for a Highway Safety Grant. Said grant is in the amount of five hundred forty-four thousand dollars and zero cents (\$544,000.00).

A copy of said Application is on file in the office of the County Administrator.

APPROVED:

THE COUNTY COMMISSION OF WOOD COUNTY

Stephen Gainer, President

David Blair Couch, Commissioner

Robert K. Tebay, Commissioner

M/3182

8/24/15
7/1/98

AUGUST 24, 2015

IN THE COUNTY COMMISSION OF WOOD COUNTY, WEST VIRGINIA

IN RE: THE COUNTY COMMISSION CALLED FOR A SPECIAL SESSION
TO BE HELD AUGUST 25, 2015 TO MAKE A SITE VISIT OF A
CONSTRUCTION SITE FOR MONDO CONSTRUCTION.

ORDER

At 9:30 A.M., the County Commission of Wood County, in regular session, announced to all concerned, upon a motion made by David Blair Couch, seconded by Robert K. Tebay and made unanimous by Stephen Gainer, announced that they, as a Commission, are calling for a Special Session to be held on Tuesday, August 25, 2015 at 11:00 A.M. Said Special Session is being held for the purpose of making a site visit of a construction site for Mondo Construction.

APPROVED:

THE COUNTY COMMISSION OF WOOD COUNTY



Stephen Gainer, President

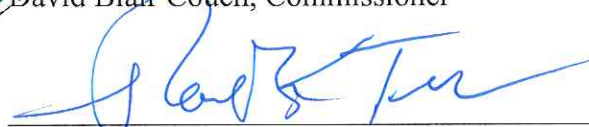

David Blair Couch, Commissioner

Robert K. Tebay, Commissioner

A/1500

8/24/15
2198

STATE OF WEST VIRGINIA
COUNTY OF WOOD

}

TO --WIT:

I, John Pfalzgraf, do solemnly swear that I will support the Constitution of the United States, the Constitution of the State of West Virginia, and that I will faithfully and impartially discharge the duties of the office of Wood County Airport Authority in and for Wood County, West Virginia, to the best of my skill and judgment, during my continuance in the same; SO HELP ME GOD.



Subscribed and sworn to, before the County Commission of Wood County, West Virginia, this 4th day of August, 2015.

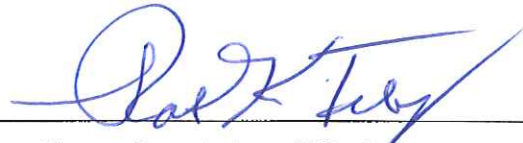

County Commission of Wood County

8/24/15

8/24/15

STATE OF WEST VIRGINIA
COUNTY OF WOOD

}

TO -WIT:

I, Terry Moore, do solemnly swear that I will support the Constitution of the United States, the Constitution of the State of West Virginia, and that I will faithfully and impartially discharge the duties of the office of Wood County Airport Authority in and for Wood County, West Virginia, to the best of my skill and judgment, during my continuance in the same; SO HELP ME GOD.

Terry H Moore

Subscribed and sworn to, before the County Commission of Wood County, West Virginia, this 4th day of August, 2015.

[Signature]

County Commission of Wood County

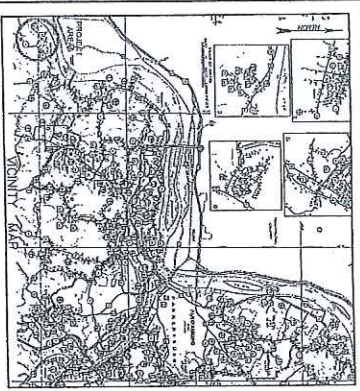

LUBECK
PUBLIC SERVICE DISTRICT
CONSTRUCTION DRAWINGS FOR
NEW ENGLAND RIVER ROAD
WATERLINE EXTENSION PROJECT
WOOD COUNTY, WEST VIRGINIA



SHEET LAYOUT

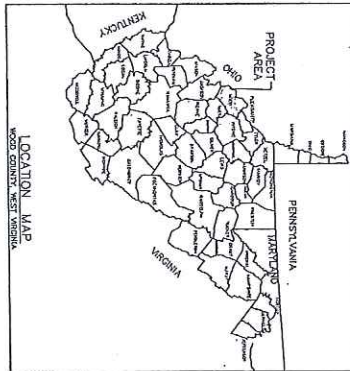

MEMBERS
JOHN H. SINES, CHAIRMAN
JERRY R. MARTIN, SECRETARY
ROGER D. MARTIN, TREASURER
RANDALL ATKINSON, GENERAL MANAGER

INDEX OF SHEETS

Title Sheet
Notes & Legend
Plan Sheets
Details

1
2-9

Charles R. Robinson Jr.
REGISTERED PROFESSIONAL ENGINEER
STATE OF WEST VIRGINIA
10424
CHARLES R. ROBINSON JR.
REGISTERED

E.L. ROBINSON
ENGINEERING
5088 Washington Street, West
Charleston, West Virginia 25313
Phone: 304-776-7473
Fax: 304-776-6425
www.elrobinsonengineering.com

PROJECT TITLE
NEW ENGLAND RIVER ROAD
WATERLINE EXTENSION PROJECT

COUNT
LUBECK
PUBLIC SERVICE DISTRICT

DATE
JUNE 2015



EQUIPMENT INDEX	
NO.	DESCRIPTION
1	CONCRETE PUMP
2	CONCRETE MIXER
3	CONCRETE TRUCK
4	CONCRETE CURB
5	CONCRETE CURB
6	CONCRETE CURB
7	CONCRETE CURB
8	CONCRETE CURB
9	CONCRETE CURB
10	CONCRETE CURB
11	CONCRETE CURB
12	CONCRETE CURB
13	CONCRETE CURB
14	CONCRETE CURB
15	CONCRETE CURB
16	CONCRETE CURB
17	CONCRETE CURB
18	CONCRETE CURB
19	CONCRETE CURB
20	CONCRETE CURB
21	CONCRETE CURB
22	CONCRETE CURB
23	CONCRETE CURB
24	CONCRETE CURB
25	CONCRETE CURB
26	CONCRETE CURB
27	CONCRETE CURB
28	CONCRETE CURB
29	CONCRETE CURB
30	CONCRETE CURB
31	CONCRETE CURB
32	CONCRETE CURB
33	CONCRETE CURB
34	CONCRETE CURB
35	CONCRETE CURB
36	CONCRETE CURB
37	CONCRETE CURB
38	CONCRETE CURB
39	CONCRETE CURB
40	CONCRETE CURB
41	CONCRETE CURB
42	CONCRETE CURB
43	CONCRETE CURB
44	CONCRETE CURB
45	CONCRETE CURB
46	CONCRETE CURB
47	CONCRETE CURB
48	CONCRETE CURB
49	CONCRETE CURB
50	CONCRETE CURB
51	CONCRETE CURB
52	CONCRETE CURB
53	CONCRETE CURB
54	CONCRETE CURB
55	CONCRETE CURB
56	CONCRETE CURB
57	CONCRETE CURB
58	CONCRETE CURB
59	CONCRETE CURB
60	CONCRETE CURB
61	CONCRETE CURB
62	CONCRETE CURB
63	CONCRETE CURB
64	CONCRETE CURB
65	CONCRETE CURB
66	CONCRETE CURB
67	CONCRETE CURB
68	CONCRETE CURB
69	CONCRETE CURB
70	CONCRETE CURB
71	CONCRETE CURB
72	CONCRETE CURB
73	CONCRETE CURB
74	CONCRETE CURB
75	CONCRETE CURB
76	CONCRETE CURB
77	CONCRETE CURB
78	CONCRETE CURB
79	CONCRETE CURB
80	CONCRETE CURB
81	CONCRETE CURB
82	CONCRETE CURB
83	CONCRETE CURB
84	CONCRETE CURB
85	CONCRETE CURB
86	CONCRETE CURB
87	CONCRETE CURB
88	CONCRETE CURB
89	CONCRETE CURB
90	CONCRETE CURB
91	CONCRETE CURB
92	CONCRETE CURB
93	CONCRETE CURB
94	CONCRETE CURB
95	CONCRETE CURB
96	CONCRETE CURB
97	CONCRETE CURB
98	CONCRETE CURB
99	CONCRETE CURB
100	CONCRETE CURB

**NEW ENGLAND RIVER ROAD
WATERLINE EXTENSION PROJECT**

PLAN SHEET

PLANS PREPARED FOR:
LURECK
PUBLIC SERVICE DISTRICT
WOOD COUNTY, WEST VIRGINIA



NO.	DATE	REVISION	BY

EL. ROBINSON
ENGINEERS
2008 Washington Street, West
Charleston, West Virginia 25313
Phone: 304-776-7412
Fax: 304-776-6418
www.elrobinsonengineers.com

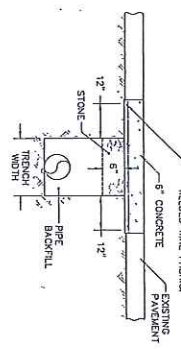
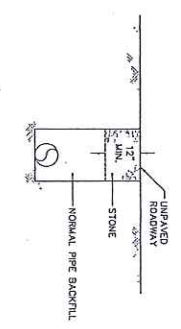
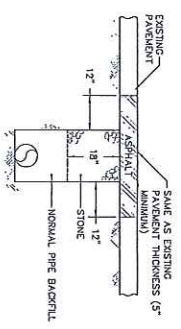
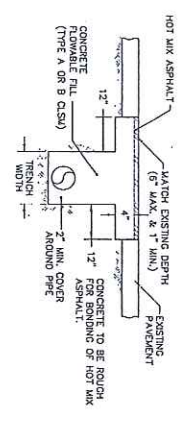

TYPE 'A' TRENCH ROADWAY REPAIR

TYPE 'B' TRENCH - ASPHALT PAVEMENT

TYPE 'C' TRENCH - UNPAVED ROAD

TYPE 'D' TRENCH CONCRETE REPAIR

NOTES:
1. TRENCHES ARE WIDER THAN 2' W. EXISTING BITUMINOUS PAVEMENT CONCRETE MAY BE DELETED IF EXISTING HOT MIX ASPHALT THICKNESS AND 18" STONE ARE MAINTAINED AT ALL TIMES BY THE USE OF APPROPRIATE TRAFFIC CONTROL DEVICES. USE OF METAL TRAFFIC CONTROL DEVICES IS NOT PERMITTED. TRENCH IS REQUIRED TO PREVENT WHEEL LOADS FROM BEING TRANSMITTED TO CURB. THE PLATES ARE TO BE SECURED BY BOLTS TO PREVENT THEM FROM BEING PULLED OUT. PLATES ARE TO BE LEFT IN PLACE UNTIL THE FLOWABLE FIL HAS OBTAINED 50% OF ITS COMPRESSIVE STRENGTH.

NOTE:
TYPE 'B' TRENCH REPAIR TO BE USED ON ALL ROADS & ASPHALT DRIVEWAYS NOT DESIGNATED AS TYPE 'A' TRENCH.

NOTE:
TYPE 'C' TRENCH REPAIR TO BE USED ON ALL GRAVEL ROADS & DRIVEWAYS.

NOTE:
TYPE 'D' TRENCH REPAIR TO BE USED ON ALL CONCRETE DRIVEWAYS & SIDEWALKS.

CARRIER PIPE	STEEL CASING	MIN. RISE DIA.
1" PER. POLYETHYLENE GLASS FIBER REINFORCED CONCRETE	NONE	NONE
2" PER. POLYETHYLENE GLASS FIBER REINFORCED CONCRETE	NONE	NONE
4" COPPER	NONE	NONE
6" PVC	4"	10 in.
8" D.I.P.	5"	12 in.
10" D.I.P.	6"	14 in.
12" D.I.P.	8"	16 in.
14" D.I.P.	10"	18 in.
16" PVC	12"	20 in.
18" D.I.P.	14"	22 in.
20" D.I.P.	16"	24 in.
22" PVC	18"	26 in.
24" D.I.P.	20"	28 in.
26" PVC	22"	30 in.
28" D.I.P.	24"	32 in.
30" PVC	26"	34 in.
32" D.I.P.	28"	36 in.

CASING WALL THICKNESS (MINIMUM)	WALL THICKNESS
10 in.	0.187"
12 in.	0.197"
14 in.	0.207"
16 in.	0.217"
18 in.	0.227"
20 in.	0.237"
22 in.	0.247"
24 in.	0.257"
26 in.	0.267"
28 in.	0.277"
30 in.	0.287"
32 in.	0.297"
34 in.	0.307"
36 in.	0.317"
38 in.	0.327"
40 in.	0.337"
42 in.	0.347"
44 in.	0.357"
46 in.	0.367"
48 in.	0.377"

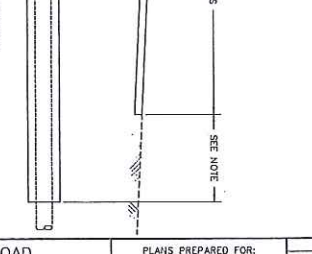
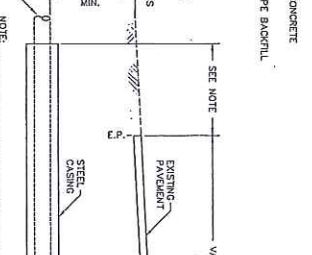
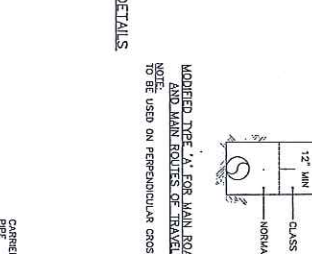

NOTE:
UNLESS OTHERWISE APPROVED BY THE ENGINEER, APPROXIMATELY 5'-0" MIN. UNLESS OTHERWISE APPROVED BY THE ENGINEER, APPROXIMATELY 5'-0" MIN. UNLESS OTHERWISE APPROVED BY THE ENGINEER, APPROXIMATELY 5'-0" MIN.

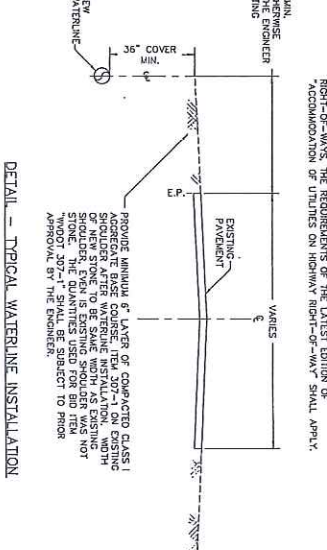
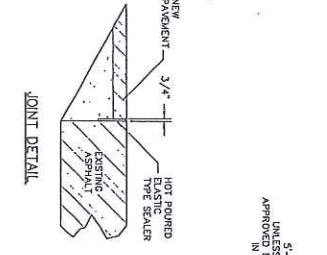
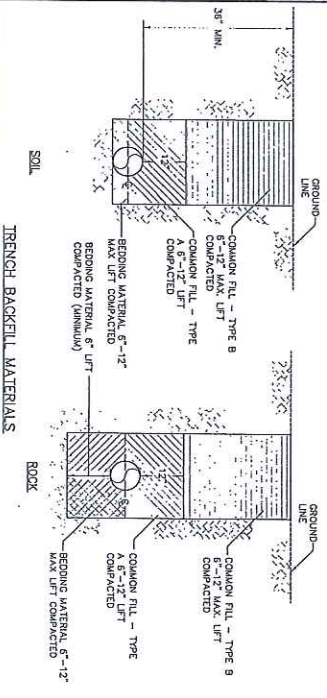

NOTE:
WITHIN THE BOUNDS OF THE DEPARTMENT OF TRANSPORTATION OR RIGHT-OF-WAYS, THE REQUIREMENTS OF THE LATEST EDITION OF ACCORDANCE WITH THE DEPARTMENT OF TRANSPORTATION OR RIGHT-OF-WAYS SHALL APPLY.

NEW ENGLAND RIVER ROAD WATERLINE EXTENSION PROJECT

WATERLINE DETAIL SHEET

PLANS PREPARED FOR: LUBECK PUBLIC SERVICE DISTRICT WOOD COUNTY, WEST VIRGINIA

NOT TO SCALE

PROJECT NUMBER: 3

SHEET NUMBER: 3

E.L. ROBINSON ENGINEERING

5088 Washington Street, West Charleston, West Virginia 25313
Phone: 304-776-4143
Fax: 304-776-6426
www.elrobinsonengineering.com

NO.	DATE	REVISION	BY

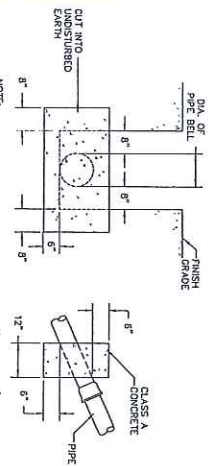

PIPE SLOPE	MIN. CON. ANCHOR SPACING
LESS THAN 20%	60 IN.
20% TO 34%	60 IN.
35% TO 49%	48 IN.
50% OR GREATER	36 IN.

CONCRETE ANCHOR FOR SLOPES

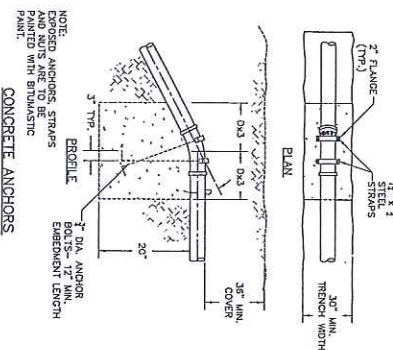

CONCRETE ANCHORS

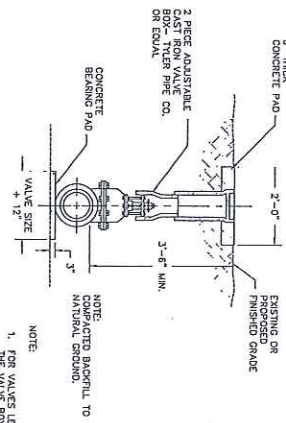

VALVE BOX INSTALLATION

- NOTE:
1. FOR VALVES LESS THAN 4 FEET DEEP THE VALVE BOX SHALL BE TWO PICES HINDS AS SHOWN.
 2. ALL VALVE BOXES SHALL BE SURROUNDED BY A 6 INCH DEEP CONCRETE PAD 2'-0" SQUARE.
 3. LOCATION WIRE TO BE PULLED INTO VALVE BOX.

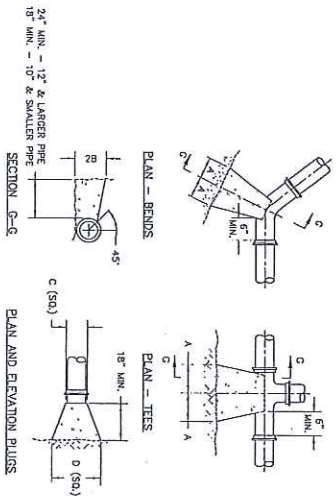

SIZE IN.	90° BENDS	45° BENDS	22.5° & 11.25° BENDS	TEES & WYES	PLUGS
A	4	4	4	A	B
B	6	6	6	A	B
C	8	8	8	A	B
D	10	10	10	A	B
E	12	12	12	A	B
F	14	14	14	A	B
G	16	16	16	A	B
H	18	18	18	A	B
I	20	20	20	A	B
J	22	22	22	A	B
K	24	24	24	A	B
L	26	26	26	A	B
M	28	28	28	A	B
N	30	30	30	A	B

NOTE: DIMENSIONS BASED UPON SOIL BEARING CAPACITY OF 100 PSI. DIMENSIONS TO BE INCREASED PROPORTIONALLY FOR HIGHER PRESSURE.

STANDARD THRUST BLOCKS FOR WATER LINES

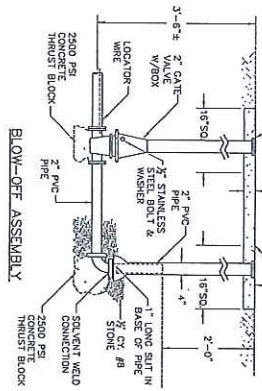

BLOW-OFF ASSEMBLY

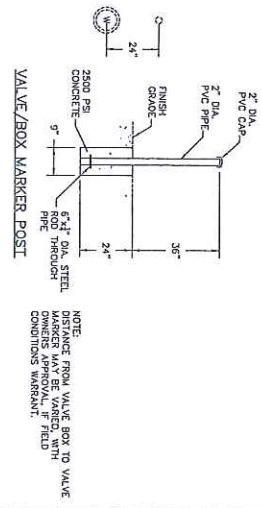

VALVE/BOX MARKER POST

NOTE: DIMENSIONS FROM VALVE BOX TO VALVE MARKER MAY BE VARIED, WITH OWNER APPROVAL, IF FIELD CONDITIONS WARRANT.

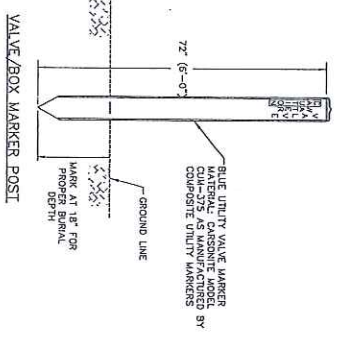

VALVE/BOX MARKER POST

NEW ENGLAND RIVER ROAD WATERLINE EXTENSION PROJECT

WATERLINE DETAIL SHEET

PLANS PREPARED FOR: LUREX PUBLIC SERVICES DISTRICT WOOD COUNTY, WEST VIRGINIA

NOT TO SCALE

NO.	DATE	REVISION	BY

E.L. ROBINSON ENGINEERING
 5088 Washington Street West
 Charleston, West Virginia 25315
 Phone: 304-776-7414
 Fax: 304-776-6426
 www.elrobinsonengineering.com

PROJECT NUMBER: 016
 DATE: JUNE 2013
 SHEET NUMBER: 4

NOTE:
DISTANCE FROM VALVE BOX TO VALVE
DANGER MAY BE VARIED WITH
OWNER'S APPROVAL AND
CONDITIONS WARRANT.

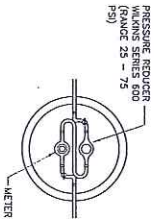

TANDEM SETTER DETAIL

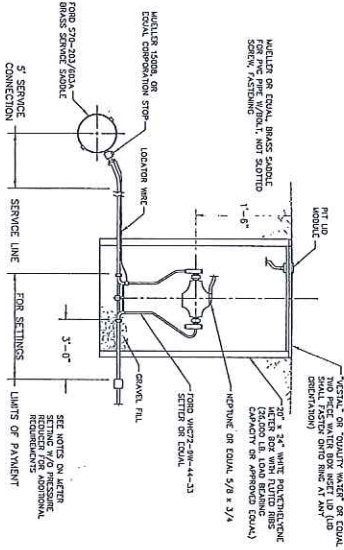

METER SETTING/SERVICE CONNECTION W/ PRV

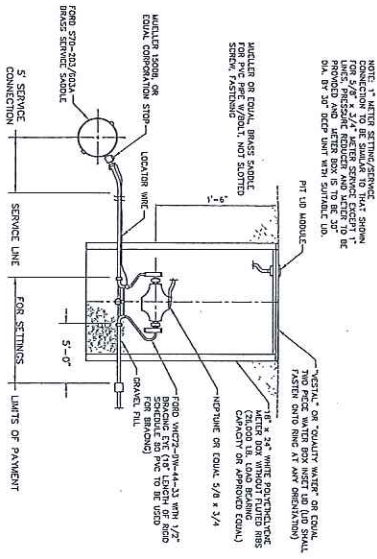

METER SETTING/SERVICE CONNECTION W/O PRV

NEW ENGLAND RIVER ROAD
WATERLINE EXTENSION PROJECT

WATERLINE DETAIL SHEET

PLANS PREPARED FOR:
LURECK
PUBLIC SERVICE DISTRICT
WOOD COUNTY, WEST VIRGINIA

NOT TO SCALE

NO.	DATE	REVISION	BY

E.L. ROBINSON
ENGINEERING
5008 Washington Street, West
Charleston, West Virginia 25313
Phone: 304-776-7473
Fax: 304-776-6476
www.elrobinsonengineering.com

PROJECT NUMBER
DATE
JUNE 2015
SHEET NUMBER
5

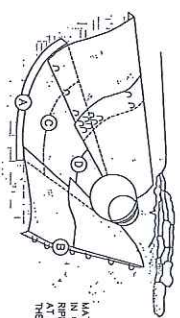

THESE CONFIGURATIONS ARE EXAMPLES ONLY. ALWAYS INSTALL PER MANUFACTURER'S SPECIFICATIONS.

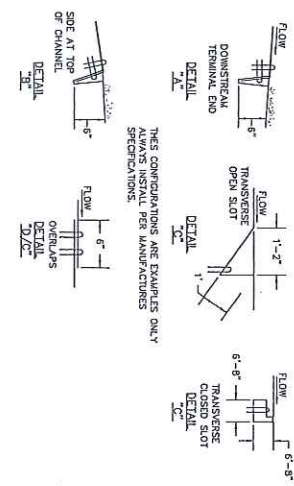

TYPICAL ROLLED EROSION CONTROL CHANNEL PROTECTION INSTALLATION

PREPARE A STABLE AND FIRM SURFACE. REMOVE DEBRIS AND OTHER OBSTRUCTIONS. APPLY FERTILIZER AND SEED AS NECESSARY TO PREPARE SEEDING. APPLY SEED AND FERTILIZER IN ACCORDANCE WITH THE PERMANENT SEEDING SPECIFICATION. TYPICALLY, STRIPS ARE UNROLLED PARALLEL TO THE PRIMARY DIRECTION OF THE INSTALLATION. DO NOT STRETCH OR ALLOW MATERIAL TO BRIDGE OVER SURFACE. UNDESIRABLE STAPLE/STAPLE REPCS TO SOIL SUCH THAT EACH STAPLE/STAPLE IS FLUSH WITH UNDERLYING SOIL. INSTALL ANCHOR TRENCHES, SCAMS AND TERMINAL ENDS AS SPECIFIED.

BMP3.13--ROLLED EROSION CONTROL PRODUCTS (RECP)

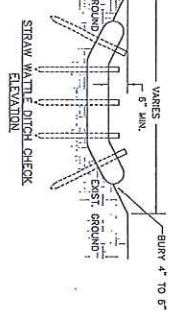
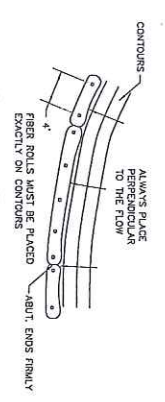
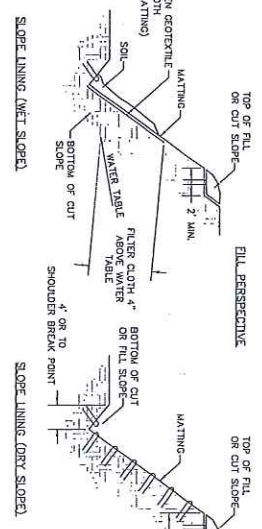
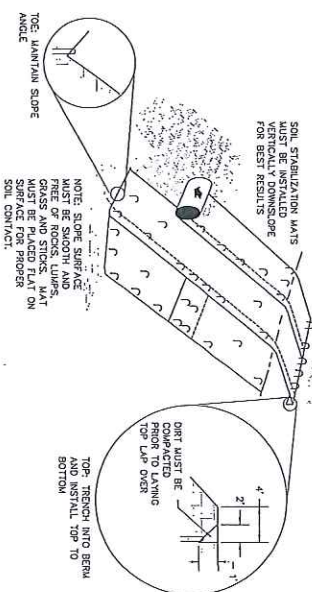

1. SHAPE AND SMOOTH THE SURFACE TO FINAL GRADE IN ACCORDANCE WITH THE APPROVED GRADING PLAN.
2. MOUND TWO INCHES (MINIMUM) OF WELL-SORTED COMPOST INTO THE TOP SIX INCHES OF THE SOIL IF FERTILIZER IS NOT APPLIED TO THE SURFACE. ESTABLISH A BUFFER ZONE WITHIN 200 FEET OF WATERBODIES AND WETLANDS. AVOID USE NON-PHOSPHORUS FERTILIZER.
3. MOUND TWO INCHES (MINIMUM) OF WELL-SORTED COMPOST INTO THE TOP SIX INCHES OF THE SOIL IF FERTILIZER IS NOT APPLIED TO THE SURFACE. ESTABLISH A BUFFER ZONE WITHIN 200 FEET OF WATERBODIES AND WETLANDS. AVOID USE NON-PHOSPHORUS FERTILIZER.
4. LAY STRIPS OF SOIL BEHIND AND TO THE DOWN-SLOPE TO BE SMOOTHED TO THE SURFACE TO THE DIRECTION OF WATER FLOW. WEAVE STRIPS SECURELY INTO PLACE. SQUARE THE ENDS OF EACH STRIP.
5. STAPLE STRIPS AT LEAST 12 INCHES. STAPLE ON SLOPES STEEPER THAN 3:1. ROLL THE SMOOTHED AREA AND REMOVE.
6. STAPLES SHOULD BE PLACED AT LEAST 12 INCHES. STAPLE ON SLOPES STEEPER THAN 3:1. ROLL THE SMOOTHED AREA AND REMOVE.
7. STAPLES SHOULD BE PLACED AT LEAST 12 INCHES. STAPLE ON SLOPES STEEPER THAN 3:1. ROLL THE SMOOTHED AREA AND REMOVE.

BMP3.14--SODDING

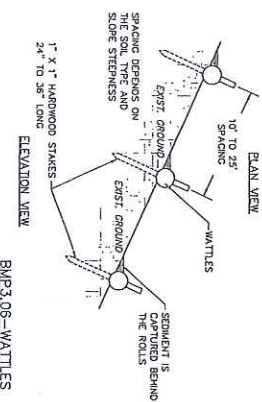

BMP3.09--WATLES

1. IT IS CRITICAL THAT WATLES BE INSTALLED PERPENDICULAR TO THE FLOW DIRECTION AND PARALLEL TO THE SLOPE CONTOUR. WATLES SHOULD BE NUC ACROSS THE SLOPE ON CONTOUR. TO A DEPTH OF 3 TO 5 INCHES ON CLAY SOILS AND SOILS WITH GRAVILLY SLOPES. ON LOOSE SOILS, STEEP SLOPES, AND DURING HIGH RAINFALL EVENTS, THE TRENCHES SHOULD BE DUG TO A DEPTH OF 5 TO 7 INCHES. ON SOFT SOILS, THE TRENCHES SHOULD BE DUG TO A DEPTH OF 5 TO 7 INCHES. ON SOFT SOILS, THE TRENCHES SHOULD BE DUG TO A DEPTH OF 5 TO 7 INCHES. ON SOFT SOILS, THE TRENCHES SHOULD BE DUG TO A DEPTH OF 5 TO 7 INCHES.
2. IT IS CRITICAL THAT WATLES BE INSTALLED PERPENDICULAR TO THE FLOW DIRECTION AND PARALLEL TO THE SLOPE CONTOUR. WATLES SHOULD BE NUC ACROSS THE SLOPE ON CONTOUR. TO A DEPTH OF 3 TO 5 INCHES ON CLAY SOILS AND SOILS WITH GRAVILLY SLOPES. ON LOOSE SOILS, STEEP SLOPES, AND DURING HIGH RAINFALL EVENTS, THE TRENCHES SHOULD BE DUG TO A DEPTH OF 5 TO 7 INCHES. ON SOFT SOILS, THE TRENCHES SHOULD BE DUG TO A DEPTH OF 5 TO 7 INCHES. ON SOFT SOILS, THE TRENCHES SHOULD BE DUG TO A DEPTH OF 5 TO 7 INCHES.
3. IT IS CRITICAL THAT WATLES BE INSTALLED PERPENDICULAR TO THE FLOW DIRECTION AND PARALLEL TO THE SLOPE CONTOUR. WATLES SHOULD BE NUC ACROSS THE SLOPE ON CONTOUR. TO A DEPTH OF 3 TO 5 INCHES ON CLAY SOILS AND SOILS WITH GRAVILLY SLOPES. ON LOOSE SOILS, STEEP SLOPES, AND DURING HIGH RAINFALL EVENTS, THE TRENCHES SHOULD BE DUG TO A DEPTH OF 5 TO 7 INCHES. ON SOFT SOILS, THE TRENCHES SHOULD BE DUG TO A DEPTH OF 5 TO 7 INCHES. ON SOFT SOILS, THE TRENCHES SHOULD BE DUG TO A DEPTH OF 5 TO 7 INCHES.
4. IT IS CRITICAL THAT WATLES BE INSTALLED PERPENDICULAR TO THE FLOW DIRECTION AND PARALLEL TO THE SLOPE CONTOUR. WATLES SHOULD BE NUC ACROSS THE SLOPE ON CONTOUR. TO A DEPTH OF 3 TO 5 INCHES ON CLAY SOILS AND SOILS WITH GRAVILLY SLOPES. ON LOOSE SOILS, STEEP SLOPES, AND DURING HIGH RAINFALL EVENTS, THE TRENCHES SHOULD BE DUG TO A DEPTH OF 5 TO 7 INCHES. ON SOFT SOILS, THE TRENCHES SHOULD BE DUG TO A DEPTH OF 5 TO 7 INCHES. ON SOFT SOILS, THE TRENCHES SHOULD BE DUG TO A DEPTH OF 5 TO 7 INCHES.
5. IT IS CRITICAL THAT WATLES BE INSTALLED PERPENDICULAR TO THE FLOW DIRECTION AND PARALLEL TO THE SLOPE CONTOUR. WATLES SHOULD BE NUC ACROSS THE SLOPE ON CONTOUR. TO A DEPTH OF 3 TO 5 INCHES ON CLAY SOILS AND SOILS WITH GRAVILLY SLOPES. ON LOOSE SOILS, STEEP SLOPES, AND DURING HIGH RAINFALL EVENTS, THE TRENCHES SHOULD BE DUG TO A DEPTH OF 5 TO 7 INCHES. ON SOFT SOILS, THE TRENCHES SHOULD BE DUG TO A DEPTH OF 5 TO 7 INCHES. ON SOFT SOILS, THE TRENCHES SHOULD BE DUG TO A DEPTH OF 5 TO 7 INCHES.
6. IT IS CRITICAL THAT WATLES BE INSTALLED PERPENDICULAR TO THE FLOW DIRECTION AND PARALLEL TO THE SLOPE CONTOUR. WATLES SHOULD BE NUC ACROSS THE SLOPE ON CONTOUR. TO A DEPTH OF 3 TO 5 INCHES ON CLAY SOILS AND SOILS WITH GRAVILLY SLOPES. ON LOOSE SOILS, STEEP SLOPES, AND DURING HIGH RAINFALL EVENTS, THE TRENCHES SHOULD BE DUG TO A DEPTH OF 5 TO 7 INCHES. ON SOFT SOILS, THE TRENCHES SHOULD BE DUG TO A DEPTH OF 5 TO 7 INCHES. ON SOFT SOILS, THE TRENCHES SHOULD BE DUG TO A DEPTH OF 5 TO 7 INCHES.
7. IT IS CRITICAL THAT WATLES BE INSTALLED PERPENDICULAR TO THE FLOW DIRECTION AND PARALLEL TO THE SLOPE CONTOUR. WATLES SHOULD BE NUC ACROSS THE SLOPE ON CONTOUR. TO A DEPTH OF 3 TO 5 INCHES ON CLAY SOILS AND SOILS WITH GRAVILLY SLOPES. ON LOOSE SOILS, STEEP SLOPES, AND DURING HIGH RAINFALL EVENTS, THE TRENCHES SHOULD BE DUG TO A DEPTH OF 5 TO 7 INCHES. ON SOFT SOILS, THE TRENCHES SHOULD BE DUG TO A DEPTH OF 5 TO 7 INCHES. ON SOFT SOILS, THE TRENCHES SHOULD BE DUG TO A DEPTH OF 5 TO 7 INCHES.

PROJECT NUMBER DATE SHEET NUMBER		NEW ENGLAND RIVER ROAD WATERLINE EXTENSION PROJECT SEDIMENT AND EROSION CONTROL DETAILS		PLANS PREPARED FOR: LURICK PUBLIC SERVICE DISTRICT WOOD COUNTY, WEST VIRGINIA		E.L. ROBINSON CIVIL ENGINEER 5088 Via Abington Street, West Charleston, West Virginia 25313 Phone: 304-776-7473 Fax: 304-776-8486 www.elrobinsoneng.com	
NOT TO SCALE		NO. DATE REVISION BY		5		5	

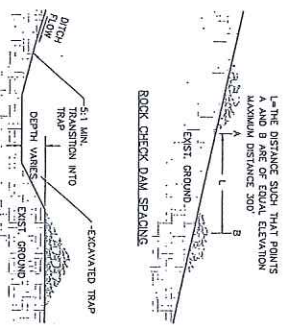
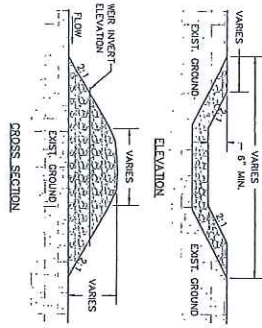

1. THE DRAINAGE AREA OF THE DITCH OR SWALE BEING PROTECTED SHALL NOT EXCEED 2 ACRES WHEN THE DRAINAGE AREA OF THE DITCH OR SWALE IS LESS THAN 2 ACRES.
2. THE DAM SHOULD BE LAID TO EXTEND THE SLOPE TO THE TOP OF CHANNEL BANKS.
3. THE CENTER OF THE CHECK DAM MUST BE AT LEAST 6 INCHES LOWER THAN THE OUTER EDGES. THIS IS THE SINGLE MOST IMPORTANT ASPECT IN THE PROPER INSTALLATION OF THE CHECK DAM.
4. EROSION CAN OCCUR OVER THE CENTER OF THE DAM, NOT AROUND THE DAMS WHERE BEHIND THE DAM THE FLOW OF WATER SHOULD BE SUCH THAT THE TOP OF THE STRUCTURE DAM ROCK CHECK DAMS IS 200 FEET.
5. THE DAM SHOULD BE LAID TO BE IN FRONT OF THE CHECK DAM, ENSURE THE MINIMUM TRANSITION FROM THE DITCH INTO THE TRAP IS A MINIMUM OF 5.1 FEET.

BMP3.05—ROCK CHECK DAMS

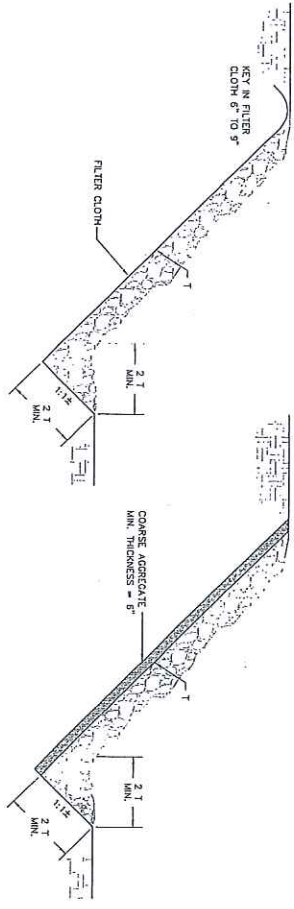

FILTER CLOTH UNDERLINER (PREFERRED)

GRANULAR FILTER

BMP3.02—TOE REQUIREMENTS FOR BANK STABILIZATION

BMP3.23.1 AASHTO RIPRAP GRADATION CLASSES

RIPRAP CLASSES	ROCK SIZE, feet (mm)	ROCK SIZE, pounds (kg)	PERCENT OF RIPRAP SMALLER THAN
A	1.25 (400) 0.75 (225) 0.40 (120)	200 (90) 5 (2) 5 (2)	100 10 10
B	1.88 (580) 1.18 (360) 0.40 (120)	500 (225) 200 (90) 5 (2)	100 10 10
C	2.25 (690) 1.88 (580) 1.18 (360) 0.40 (120)	1000 (450) 500 (225) 200 (90) 5 (2)	100 50 10 10
D	2.25 (690) 1.88 (580) 1.18 (360) 0.40 (120)	1000 (450) 500 (225) 200 (90) 5 (2)	100 50 10 10
E	2.25 (690) 1.88 (580) 1.18 (360) 0.40 (120)	1000 (450) 500 (225) 200 (90) 5 (2)	100 50 10 10
F	4.50 (1370) 2.25 (690) 1.88 (580) 1.18 (360) 0.40 (120)	4000 (1800) 1000 (450) 500 (225) 200 (90) 5 (2)	100 50 10 10 10

1 Assuming a specific gravity of 2.65.
2 Based on ASTM gradations.

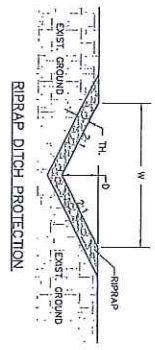

RIPRAP DITCH PROTECTION

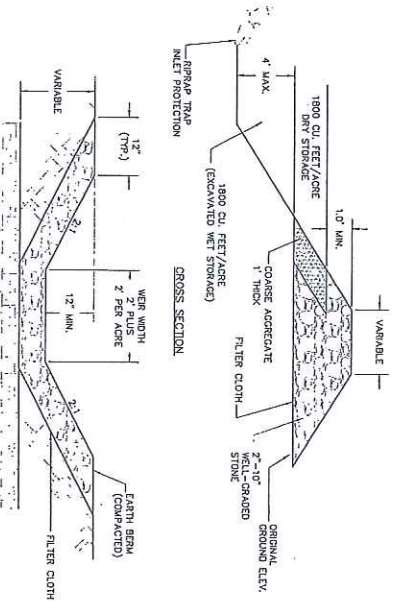

BMP3.09.1 ROCK OUTLET SEDIMENT TRAP

<p>NEW ENGLAND RIVER ROAD WATERLINE EXTENSION PROJECT</p> <p>SEDIMENT AND EROSION CONTROL DETAILS</p>		<p>PLANS PREPARED FOR: LURECK PUBLIC SERVICES DISTRICT WOOD COUNTY, WEST VIRGINIA</p>	<p>NOT TO SCALE</p>	<p>NO. DATE REVISION BY</p>	<p>E.L. ROBINSON ENGINEERING</p> <p>5058 Washington Street, West Charleston, West Virginia 25313 Phone: 304-775-4712 Fax: 304-775-4728 www.elrobinsonengineering.com</p>
PROJECT NUMBER	DATE				
SHEET NUMBER					

1. THE MINIMUM VEGETATIVE BUFFER WIDTH SHALL BE 100 FEET, UNLESS SPECIFIC DESIGN INFORMATION CAN BE PROVIDED TO ALTERNATE A SMALLER BUFFER WIDTH. FOR SLOPES GREATER THAN 10 PERCENT, THE MINIMUM DISTANCE IS 250 FEET. SMALLER BUFFERS MAY BE USED IN CONJUNCTION WITH OTHER BMPs.
2. BUFFERS MAY BE USED AS A SUPPLEMENT TO OTHER BMPs FOR WATERSHEDS THAT EXCEED 200 FEET UNLESS DITCH-OSSERVING DEVICES ARE PROVIDED.
3. (GOOD) (MINIMUM OF 80%) VEGETATIVE COVER MUST BE PRESENT IN THE PROPOSED BUFFER AREA.

BMP3-25-VEGETATIVE BUFFER STRIP

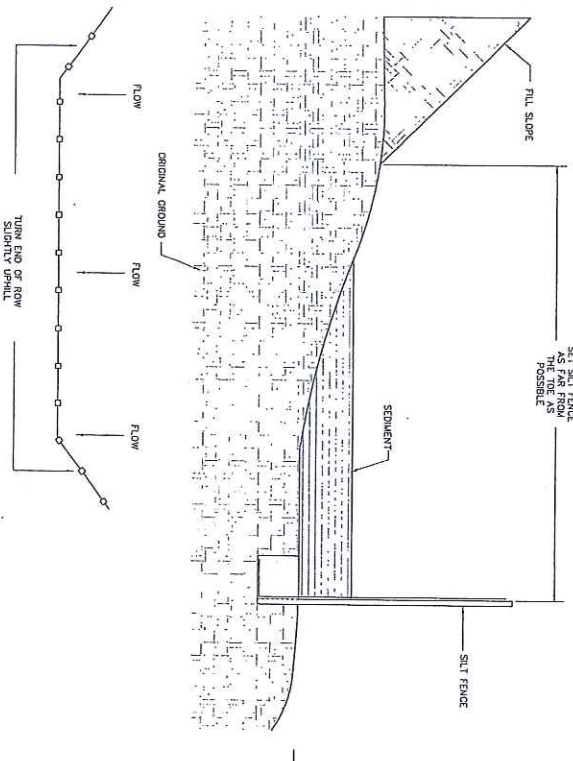

NOTE:
THE MAXIMUM LENGTH OF SLOPE ABOVE A 10' SILT FENCE IS 10'.

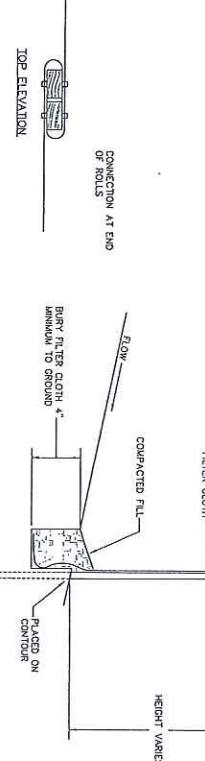
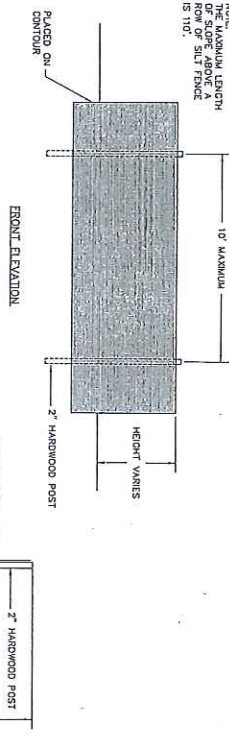

BMP3-27.2 SILT FENCE

BMP3-27.1 PLACEMENT OF SILT FENCE

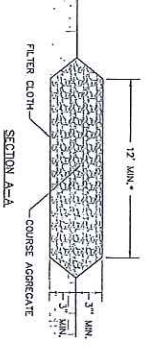
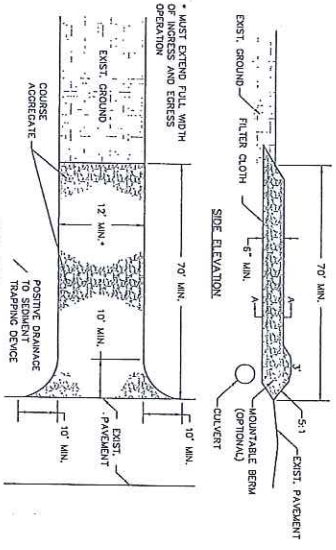
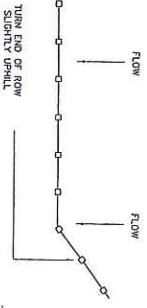

1. USE 3/4" MESH STONE FOR LOW VOLUME ENTRANCES, LARGER STONE (4"-6" INCH) FOR HEAVY USE OR MATERIAL BEYOND ENTRANCES.
2. LENGTH IS AS REQUIRED, BUT NOT LESS THAN 70 FEET (EXCEPT ON A SINGLE RESIDENCE LOT WHERE A 20 FOOT MINIMUM LENGTH WOULD APPLY).
3. THE WIDTH SHALL BE A MINIMUM OF 12 FEET, BUT NOT LESS THAN THE FULL WIDTH AT POINTS WHERE COURSES OF FERRIS OCCURE.
4. PLACED OVER THE ENTIRE AREA, PRIOR TO THE PLACING OF STONE.
5. ALL SURFACE WATER FLOWING OR DIVERTED TOWARD CONSTRUCTION ENTRANCES SHALL BE SPREAD ACROSS THE ENTRANCE. IF A CULVERT IS IMPRACTICAL, A MOUNTABLE BERM WITH 5:1 SLOPES SHALL BE NECESSARY, DIVERT ANY WATER RUNNING DOWN ACCESS ROAD TO A SEDIMENT TRAP LOCATED ON EITHER SIDE OF THE STABILIZED CONSTRUCTION ENTRANCE.
6. IF NECESSARY, DIVERT ANY WATER RUNNING DOWN ACCESS ROAD TO A SEDIMENT TRAP LOCATED ON EITHER SIDE OF THE STABILIZED CONSTRUCTION ENTRANCE.

BMP3-02-STABILIZED CONSTRUCTION ENTRANCE

E.L. ROBINSON ENGINEERING
 5528 Washington Street, West
 Charleston, West Virginia 25313
 Phone: 304-776-7473
 Fax: 304-776-6426
 www.elrobinsonengr.com

NO.	DATE	REVISION	BY

PLANS PREPARED FOR:
 LUREX
 PUBLIC SERVICE DISTRICT
 WOOD COUNTY, WEST VIRGINIA

GRAPHIC SCALE
 NOT TO SCALE

NEW ENGLAND RIVER ROAD WATERLINE EXTENSION PROJECT

SILT FENCE DETAILS

PROJECT NUMBER
 DATE
 JUNE 2015
 SHEET NUMBER
 8